



Ver. 2008

Trunnion Ball Valve

INSTALLATION, OPERATION AND
MAINTENANCE MANUAL

FBV/IOM/BA02

FBV[®]
Engineered Solutions
FBV INC.

TABLE OF CONTENTS

1 APPLICATIONS.....2

1.1 Applications.....2

1.2 Performance Specifications.....2

2 APPLICABLE STANDARDS.....2

3 DESIGN FEATURES AND FUNCTION.....3

3.1 Body Design.....3

3.2 Block and Bleed3

3.3 Unique Sealing Configuration3

3.4 Emergency Seal3

3.5 Fire Safe Design3

3.6 Anti-Static Design3

3.7 Locking Device3

3.8 Leakage Free Cover Flange Design4

3.9 Full Port and Reduced Port4

4 VALVE EXPLODED VIEW.....5

5 INSTALLATION, DEBUGGING AND USAGE6

6 MAINTENENCE8

6.1 Reservation8

6.2 Heavy Repair8

7 DISASSEMBLING.....8

8 ASSEMBLING.....9

9 TROUBLE SHOOTING11

10 CAUTIONS11

APPENDIX I – GENERAL ARRANGEMENT DRAWINGS.....13

1 APPLICATIONS

1.1 Applications

This series of trunnion ball valves are applicable for natural gas industry, petroleum products, petrochemical industry, metallurgy, city construction, environment protection, pharmaceutical, food industry etc. The sulfur resisting valves of this series are mostly used for natural gas pipeline transmission of media containing hydrogen sulphide and more contaminants, or high corrosive medium.

1.2 Performance Specifications

Size		NPS	
Pressure		Class	
Test Pressure	Shell (Water)	1.5 x PN*	Mpa
	Seat Test (Air)	0.6	
	HP Seat Test (Water)	1.1 x PN*	
Temperature Range		Depends on the selected materials	

* PN = the working pressure at the specified Class under -29 to 38 deg. C.

2 APPLICABLE STANDARDS

- API Spec 6D *Pipeline Valves*
- API Std 608 *Metal Ball Valves – Flange, Threaded and Welding Ends*
- API Std 598 *Valve Inspection and Testing*
- API Spec 6FA *Specification for Fire Test for Valves*
- ASME B16.34 *Valves – Flanged, Threaded and Welding Ends*
- ASME B16.5 *Pipe Flanges and Flanged Fittings*
- ASME B16.47 *Large Diameter Steel Flanges*
- ASME B16.25 *Buttwelding Ends*
- ASME B16.10 *Face-to-Face and End-to-End Dimensions of Valves*
- MSS SP-25 *Standard Marking System for Valves, Fittings, Flanges and Unions*

3 DESIGN FEATURES AND FUNCTION

3.1 Body Design

The body of trunnion mounted ball valves can be designed according to customers' requirements and actual working conditions. The body can be casting, forging and fully welded which is mainly used for underground service.

3.2 Block and Bleed

When the valve is in fully closed position, pressure on each side of the ball is blocked by upstream and downstream seats, a drain valve is installed at the bottom of valves for draining and cleaning dirt.

3.3 Unique Sealing Configuration

For trunnion ball valve, different sealing configuration can be selected based on pressure rating, media property and sealing requirement, they are Pre-Ball Configuration, Post-Ball Configuration and Pre- and Post-Ball double seal configuration.

3.4 Emergency Seal

When seat and stem seal wears out, which causes leakage, an emergency sealant can be injected via sealant injection valve to restore seal temporarily.

3.5 Fire Safe Design

Based on working condition and customers' need, ball valves can be design to be fire proof, of which the design as per API 6FA and API 607. Once their is a fire which will burn out the soft seal ring, fire safe design will effect and protect from mass leakage, thus does the best to stop the fire from expanding.

3.6 Anti-Static Design

When operating the valve, the ball and seat scrub each other, which generates electrostatic charge accumulating on the ball. To stop the electrostatic from causing static breeze, an anti-static device is applied to lead out the electricity.

3.7 Locking Device

In fully open and fully closed position of manual operated ball valves, a locking

device can be design and applied on. In this case, it can prevent misoperation and unexpected open/close caused by pipeline vibration, especially in transmission line of flammable medium such as oil and chemical. It is a better choice when the valve is for outdoor installation.

3.8 Leakage Free Cover Flange Design

Gasket is used for sealing between body and bonnet connection, to prevent leakage from fire, high-temperature, vibration or unequal open and close torque, etc., body and bonnet is designed metal-to-metal contact to ensure no leakage.

3.9 Full Port and Reduced Port

The bore of full opening valve is of the same diameter as the pipe inside diameter, this reduces backset and it is easy to clean the pipe.

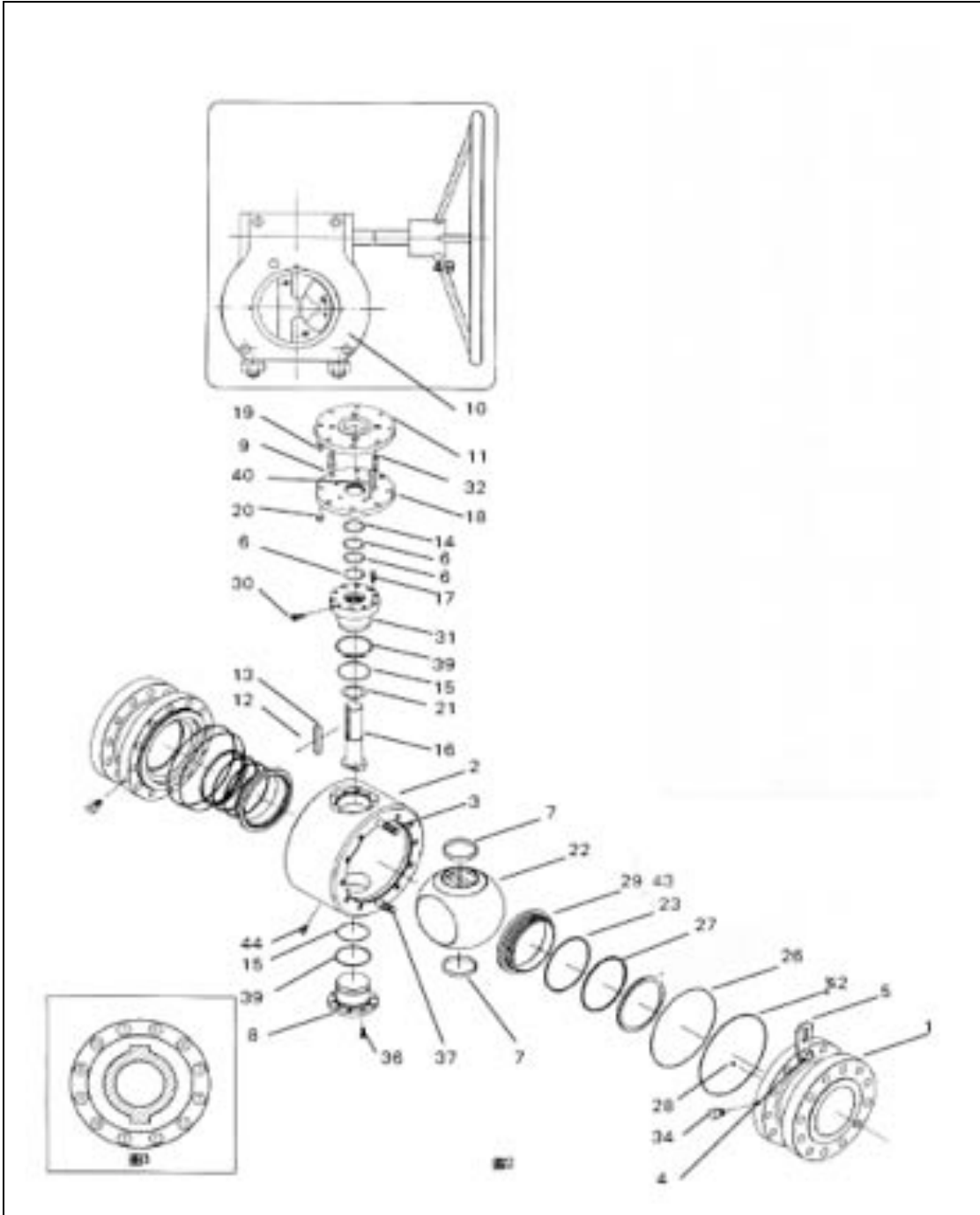

Figure 2

5 INSTALLATION, DEBUGGING AND USAGE

5.1 Seat and body pressure rating determine the safe use of this valve, please go through the nameplate carefully to know the two ratings. There are varies kinds of

materials for seat, some has lower rating than body. Pressure rating of seat and body is selected based on valve type, size, seat material, bolting material and temperature, do not exceed the rating in using the valves.

- 5.2 This series of valves is design and manufactured according to API 6D, if not otherwise specified, shell test pressure is 1.5 time of body pressure rating while seat test is of 1.1 times, and air test pressure is 0.6Mpa. For test duration and test method, please refer to API 598.
- 5.3 It is recommended to perform the pressure test before installation, if otherwise requested, stick to the purchase order.
- 5.4 Before installation, the valves shall be in open position.
- 5.5 Identity if there is flow arrow marked on the valve body, if not, media can go in either side and valve can be installed horizontally or vertically, otherwise, please pay attention to the flow direction.
- 5.6 Take notice to warnings on the valve. Take off the covers on both sides as well as the drier in the cavity.
- 5.7 Before installing the valve to the pipeline, apply some grease in the sealant injection valve of the stuffing box for easy operation.
- 5.8 When installing welding ended valves to the pipeline, it is necessary that the sealing faces shall be protected properly, or example, paint the seat ring with enough grease, to protect the seal from being damaged by spatter.
- 5.9 Arc welding is recommended for base of pipeline welding.
- 5.10 For welding ended valves, sleeves shall be applied to make the distance between welding and valve longer to reduce the possibility of welding spatters intruding.
- 5.11 For flange ended valves, companion flanges shall be welded to the pip, clean the welding spatter in the pipe, then install the ball valve. It is prohibited to install the companion flange to the valve first and weld the flange to the pipe later, which may cause the seal face to be damaged by spatters.
- 5.12 For flange ended valves, matching gasket, bolts and nuts shall be applied. Install the flange bolts as shown in Figure 3, or according to manufacturer recommended method.
- 5.13 It is recommended that the bypass valves to be installed when cleaning the main pipeline.

- 5.14 Before pressure testing and debugging, pipeline shall be cleaned. Do not operate the valve before cleaning; otherwise, some solid contaminant may damage the sealing face that will cause leakage. When cleaning, all the valves shall be in fully open position.
- 5.15 After pressure test on pipeline finished, the drain valve on the valve bottom shall be opened, after draining medium and all dirt, close it.
- 5.16 Operate the valve according to technical procedure, this valve is for on-off use (fully open, fully close) only, and cannot be used for regulating.
- 5.17 The valve shall be maintained periodically, for long-term unused valve, it shall operate once or twice as per technical needs. This is to make sure the valve will work normally.

6 MAINTENENCE

6.1 Reservation

- A. Ball valve shall be in full open position, to be stored in dry and ventilating place.
- B. Pay attention that the plastic covers in both ends shall not fall off, this is to prevent contaminant from intruding and scratching the flange sealing face.

6.2 Heavy Repair

Heavy repairs include replacing seat, ball (as requested) and each gasket, O-ring, etc. For replacing process, please refer to Disassembling and Assembling.

7 DISASSEMBLING

7.1 Place the valve on worktable, pay attention not to damage the flange sealing face, make clockwise rotate to close the valve.

7.2 Lever Operated Valve (See Figure 1)

- 7.2.1 Dismantle the bolt (49), indicator (45), gasket (46), lever (47) and key (13)
- 7.2.2 Dismantle bolts near stopper (32) and stopper (48).

7.3 Gear Operated Valve (See Figure 2)

- 7.3.1 Dismantle bolts (20) of mounting bracket (18), lift the gearbox as together with mounting bracket (18) from the valve, put to some place clean.
- 7.3.2 Dismantle stem bolt (12), key (13) and pin (40)

7.3.3 Dismantle the bolt (32) of mounting bracket (18), mounting bracket (18) and packing (14), put them together with gearbox.

7.4 Dismantle the nut (4) and lift lug (5) in left and right body.

7.5 Dismantle gently the left/right body (1) together with spring (28), seat ring (43), seat (29) and O-ring (23) (26), and put them on soft cloth or on hardboard; end flange face down, pay attention not to damage sealing face of flange.

7.6 Dismantle the seat, O-ring, seat ring, spring from the left/right body.

7.7 Dismantle bolts and lifting lug of left/right body of the other side, lift the middle body vertically, put it on soft clean cloth or hardboard (for big size valve, lifting with rope through ball bore is allowable), pay attention not to damage ball surface and bolts.

7.8 Repeat step 4.6, dismantle the other left/right body.

7.9 Place a cork under the ball to prevent from scratching; for big size valves, it is allowable to lift the ball with a rope going through the ball (22) bore, after that, dismantle the stuffing box and trunnion.

7.10 Dismantle the bolts (17) off the stuffing box, remove the stuffing box (31) together with stem (16), thrust ring (21), O-ring (6) (15), gasket (39) from the body.

7.11 Remove the stem, thrust ring, O-ring and gasket from stuffing box.

7.12 Dismantle the bolts (36) of trunnion, remove the trunnion (8) together with O-ring (15) and gasket (39) from the body.

7.13 Remove the ball from the body carefully, put them on soft clean cloth or hardboard; for big size valve, it is allowable to lift the ball with a rope going through the ball (22) bore, pay attention not to damage the ball surface, the chamfered edge and corner between ball and bore.

8 ASSEMBLING

8.1 Before assembling, clean all the parts, check damages, if so, repair or replace them.

8.2 Insert the spring (28) to the hole on the ball (22) (2"~ 4") and install the ball to the body (2), align the trunnion hole of ball to that of body. Place a wood under ball to prevent it from damaging; for big size valve, the ball shall be lifted in to the body, the lifting rope shall not be released until the trunnion and stuffing box is installed.

8.3 Install the gasket (39) and O-ring to the trunnion (8). Apply some lubricant to the

O-ring, pay attention not to damage it. Install the trunnion to the body, mount the screws (36).

8.4 Install the gasket (39), O-ring (15) (6), thrust ring (21) and stem (16) to the stuffing box (31), apply some lubricant to the O-ring, install this component to the body, note that flat head of the stem shall be into the slot of the ball.

8.5 Mount the screws (17), fastening it, rotate the ball to the close position.

8.6 Install the spring (28) to the holes of left/right body (1), apply the gasket (42) and O-ring to the left/right body, apply some lubricant to the O-ring. Apply washer (23), gasket (23) and seat ring (43) to the seat, apply some lubricant to the O-ring. Install this component to the left/right body, apply some pressure to seat ring till it touches the spring.

8.7 Attach the middle body (2) to one the of left/right bodies, pay attention to the direction of the sealant injection valve of the left/right bodies (see assembly drawing). Install the nuts (4) and lifting lug. Rotate the other one of left/right body over, attach it to the middle body, then install the nuts and lifting lug. For big size valve, it is allowable to use a rope through the ball bore, lift the middle body to the left/right body.

8.8 Lever operated valves (see figure 1):

8.8.1 Install the stopper 948) and screws (32) and fasten it.

8.8.2 Install the key (13) to the stem slot, then install in order the lever (47), position indicator (45), washer (46) and screws (49) and fasten it, rotate the lever, the ball shall move smoothly, and position shall be indicated correctly.

8.9 Gear operated valves (see figure 2):

8.9.1 Install the gland follower (14), mounting board (18), pin (40) and screws (32) and fasten it.

8.9.2 Install the key (13) to the stem slot, then install the screws (12) and fasten it.

8.9.3 Install the gearbox (10) together with mounting board (11) to the other board on top of the stem, pay attention to that the key and slot of gearbox shall match each other. Then install the nuts (20).

8.9.4 Rotate the handwheel, the ball shall move smoothly; adjust the limit screw on the gearbox to make the open/close position meet with the requirement, detailed steps as follows:

A. Remove the cover screw and cover from the gearbox, the key slot will appear,

unfasten two lock nuts and limit screw of the gearbox.

- B. Verify that the key slot of the axis hole is vertical to the valve bore (closed position), if not, rotate the handwheel to adjust to the right position, then fasten one of the limit screws (near the handwheel), fasten the lock nut after.
- C. Rotate the handwheel counter clockwise, make sure the ball bore is aligned to the body bore, then fasten one of the limit screws, fasten the lock nut after.
- D. Install the cover and screw back, fasten the screws.

9 TROUBLE SHOOTING

Malfunction	Possible Cause	Remedial Action
Valve will not rotate or operate	1. Packing too tight	1. Unfasten the nut and readjust
	2. Damages or dirt between stem and other parts	2, Dismantle, repair and clean the dirt
	3. Open/close exceed the limit times	
Leakage in sealing faces	1. Pretightening force not enough	1. Increase pretightening force
	2. Damages or dirt in sealing faces	2. Repair, replat the faces and clean the dirt
	3. Sealing faces distorted or failed	
Leaking in stem packing	1. Packing pretightening force not enough	1. Replace the nuts and bolts
	2. Packing failed after long time use	2. Replace the packing
Leakage between cover flanges	Bolting of cover flanges loose	Refasten the bolts & nuts of cover flanges

10 CAUTIONS

10.1 Release the pressure of pipeline and valves with following procedure:

- A. Open the valve, release the pipeline pressure
- B. In order to release all the pressure remaining in the valve cavity, before removing the valve from pipeline, it is necessary to close and open the valve again and leave the valve in open position.

- C. Before disassembling, put the valve vertically on the worktable, open and close the valve repeatedly for a few times, release or drain all the remaining media.
- 10.2 The type of valve is designed in consideration of normal working condition, please specify in the purchase order if it is specially required.
- 10.3 The actual range of working temperature shall not exceed the ratings specified in performance specifications, users shall be held responsible for consequences cause by exceeding (including instant exceeding) the regulated ratings.
- 10.4 The surface temperature during valve working in pipeline might hurt people, users shall setup relevant warning signs in proper positions.
- 10.5 Welding repair or surface painting is not allowed when the valve is in operation.
- 10.6 It is not allowed to disassemble the valve under pressure.
- 10.7 Valve shall be repaired according the Table of Material specified in point 4.
- 10.8 User shall examine and replace (when necessary) the valve periodically.

APPENDIX I – GENERAL ARRANGEMENT DRAWINGS



FBV Inc.

— **New York**
41-22 Fuller Place
Add Flushing, NY 11355, USA
Tel (347) 535-0788
Fax (347) 438-3221
sales@fbvalve.com

— **Houston**
2121 Brittmoore Rd. Suite 500
Add Houston, TX 77043, USA
Tel Tel: (832) 203-5459
Fax Fax: (832) 203-5461
sales.us@fbvalve.com

www.fbvalve.com