



TRUNNION
BALL VALVE

BA-1401D (EN)

ABOUT US

FBV Inc. is an ISO 9001 certified company specializing in manufacturing industrial valves including ball valves, gate valves, globe valves, check valves, plug valves and butterfly valves in carbon steel, stainless steel, duplex stainless and alloy materials. Our products conform to the latest industry standards in accordance to ANSI, ASME and API.

FBV today has over 600,000 square feet of manufacturing facilities. Through its conviction to provide only the finest quality products and services to match the need of our customers, FBV has now established itself as a serious player in the valve business.

FBV INC has sold worldwide in North America, Europe, South America, South Asia, Africa and the Middle East. We consider product quality and customer satisfaction as our highest priority. We look forward to new customer relationships by providing value, quality, customer service, honesty, integrity and the commitment to maintain product consistency with each and every order.

MISSION STATEMENT

We at FBV, Inc. commit to taking ACTION:

- Adopt the latest technology to take the product quality to the next level;
- Consistently provide on-time services to our customers;
- Train and develop talented people with strong work ethics to deliver effective performance;
- Improve and enhance engineering designs to ensure product performance;
- Optimize management systems and increase productivity;
- Never forget our customer and employee needs.



TRUNNION BALL VALVE

TABLE OF INDEX	PAGE
Introduction, <i>Features</i>	3-4
Scope of Products, <i>Split Body</i>	5
Scope of Products, <i>Welded Body</i>	6
Overview, <i>2-Piece Split Body</i>	7
Overview, <i>3-Piece Split Body</i>	8
Overview, <i>Welded Body</i>	9
Dimensions and Weights, <i>Class 150 (PN 20)</i>	10-11
Dimensions and Weights, <i>Class 300 (PN 50)</i>	12-13
Dimensions and Weights, <i>Class 600 (PN 100)</i>	14-15
Dimensions and Weights, <i>Class 900 (PN 150)</i>	16
Dimensions and Weights, <i>Class 1500 (PN 250)</i>	17
Dimensions and Weights, <i>Class 2500 (PN 420)</i>	18
Top Mounting Dimensions and Torque	19-23
Gear Operators, <i>Dimensions and Weights</i>	24
Seat and Seal Material, <i>Selection Guide</i>	25
Flow Coefficient, <i>Specification Table</i>	26
Valve Figure Number, <i>How To Order</i>	27-28

This page is intentionally left blank.



INTRODUCTION

A ball valve is a valve with a spherical disc, the part of the valve which controls the flow through it. The sphere has a hole, or port, through the middle so that when the port is in line with both ends of the valve, flow will occur. When the valve is closed, the hole is perpendicular to the ends of the valve, and flow is blocked.

A trunnion ball valve has additional mechanical anchoring of the ball at the top and the bottom, suitable for larger and higher pressure services. To ensure tight sealing at low pressure, high-tensile springs force the seats against the ball while at higher pressure, the medium pressure pushes upstream seat towards the ball.

EMERGENCY SEALS

For trunnion mounted ball valve size NPS 6 (DN 150) and above, it comes with provisions for sealant injection on both the stem and seat while for sizes NPS 5 (DN 125) and below on body cavity. In case of failed underperformed seals, a temporary emergency seal can be achieved by injecting sealants.

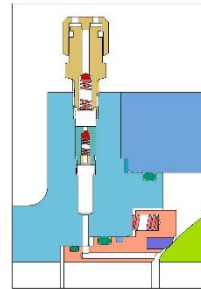

Seat Sealant Valve

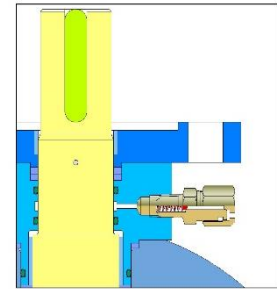

Stem Sealant Valve

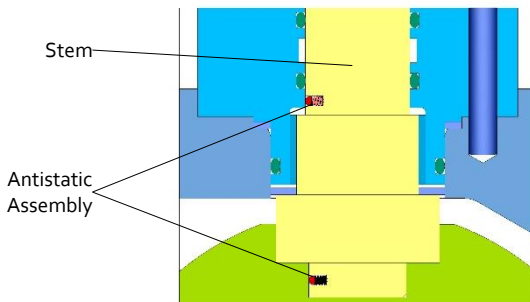

ANTI-STATIC

Because the ball and stem in a ball valve are suspended on non-metallic parts, i.e. the seat seal and stem seal, there is a possibility a static charge may build up on the stem-ball, a mechanical (antistatic metal spring and ball) is introduced in the design to maintain the metal-to-metal contact between the rotating ball/stem and the valve body which will ground any charges to the valve body.

BLOWOUT PROOF STEM

The valve stem is made with a shoulder at the bottom end. It's securely retained by the stuffing box, to avoid that the stem, under certain operating conditions, accidentally blows out. Other designs are available on request.

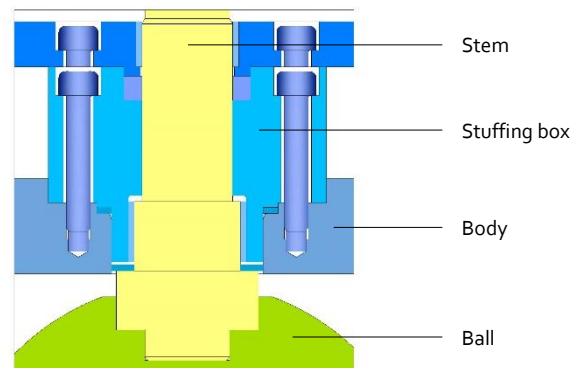

TRUNNION BALL VALVE

INTRODUCTION (CONT'D)

FEATURES

SINGLE PISTON EFFECT

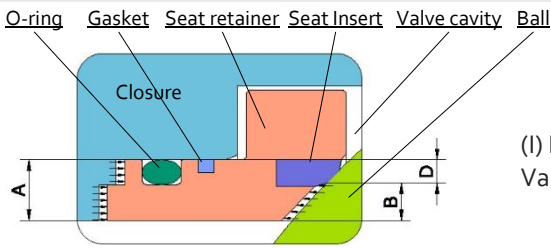

(I) Downstream Valve Seat

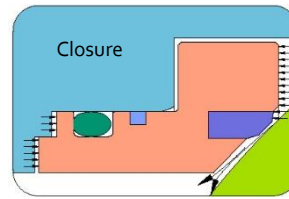

(II) Upstream Valve Seat

The difference in area (D) times the line pressure creates a "piston effect" force which pushes the seat against the ball surface resulting in a tight effect seal.

When the pressure in the valve cavity reaches a level that the total force from cavity acting on the seat is larger than the total force from upstream line pressure, the seat will be pushed away from the ball to relieve the valve cavity pressure.

DOUBLE PISTON EFFECT

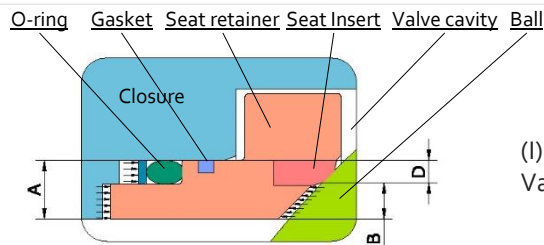

(I) Downstream Valve Seat

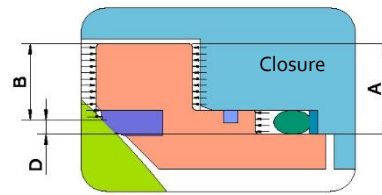

(II) Upstream Valve Seat

The different in area (D) times the line pressure creates a "piston effect" force which pushes the seat against the ball surface resulting in a tight seal.

The difference in the area (D) times the cavity pressure creates a "piston effect" force which pushes the seat against the ball surface resulting in a tight seal.

FIRE SAFE DESIGN

During a fire, non-metallic soft material will be burnt, subsequently seat leakage or external leakage may occur and cause the fire spread or contaminate the environment. FBV ball valves are fire tested in accordance with API 6FA or API 607, witnessed and certified by TUV SUD. If valve is not covered according to the standards, they are designed to be fire safe.

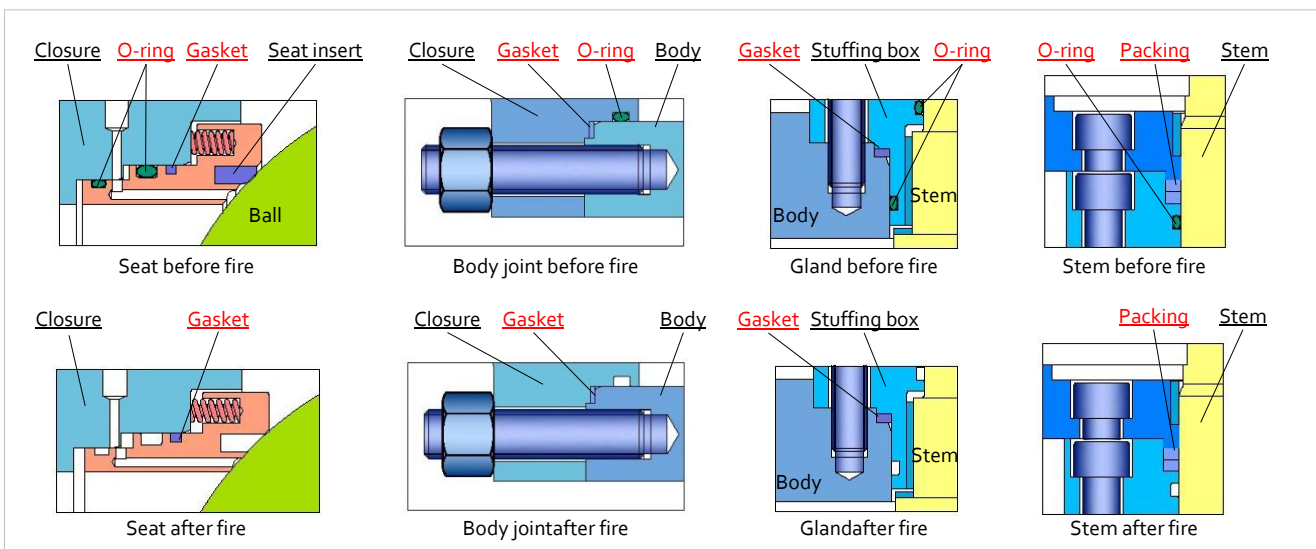

TRUNNION BALL VALVE

SCOPE OF PRODUCTS

SPLIT BODY

Legends: A – Available in Casting and Forging
 B – Available in Casting Only
 C – Available Forging Only
 D – Not Usually Required
 E – Casting Not Recommended

Size in/mm	Class 150 PN 20	Class 300 PN 50	Class 600 PN 100	Class 900 PN 150	Class 1500 PN 250	Class 2500 PN 420
1/2						
15						
3/4						
20						
1						
25						
1 1/2	A, E	A, E	A, E	A, E	A, E	C
40						
2	A	A	A	A, E	A, E	C
50						
2.5	A	A	A	A, E	A, E	C
65						
3	A	A	A	A, E	A, E	C
80						
4	A, D	A, D	A, D, E	A, D	A, D, E	C, D
100						
6	A	A	A	A, E	A, E	C
150						
8	A	A	A	A, E	A, E	C
200						
10	A	A	A	A, E	A, E	C
250						
12	A	A	A	A, E	A, E	C
300						
14	A	A	A	A, E	A, E	C, D
350						
16	A	A	A	A, E	A, E	C, D
400						
18	A	A	A	A, E	A, E	C, D
450						
20	A	A	A	A, E	A, E	C, D
500						
22	A	A	A	A, E	A, E	C, D
550						
24	A	A	A	A, E	A, E	C, D
600						
26	A	A	A	A, E	A, E	C, D
650						
28	A	A	A	A, E	A, E	C, D
700						
30	A	A	A	A, E	A, E	C, D
750						
32	A	A	A	A, E	A, E	C, D
800						
34	A	A	A	A, E	A, E	C, D
850						
36	A	A	A	A, E	A, E	C, D
900						
38	A, E	A, E	A	A, E	A, E	C, D
950						
40	A, E	A, E	A	A, E	A, E	C, D
1000						
42	A, E	A, E	A	A, E	A, E	C, D
1050						
48	A, E	A, E	A	A, E	A, E	C, D
1200						
56	A, E	A, E	A			
1400						

TRUNNION BALL VALVE

SCOPE OF PRODUCTS

WELDED BODY

Legends: A – Available in Casting and Forging
 B – Available in Casting Only
 C – Available Forging Only
 D – Not Usually Required
 E – Casting Not Recommended

Size in/mm	Class 150 PN 20	Class 300 PN 50	Class 600 PN 100	Class 900 PN 150	Class 1500 PN 250	Class 2500 PN 420
1/2						
15						
3/4						
20						
1						
25						
1 1/2	C	C	C	C	C	C
40						
2	C	C	C	C	C	C
50						
2.5	C	C	C	C	C	C
65						
3	C	C	C	C	C	C
80						
4	C,D	C,D	C,D	C,D	C,D	C,D
100						
6	C	C	C	C	C	C
150						
8	C	C	C	C	C	C
200						
10	C	C	C	C	C	C
250						
12	C	C	C	C	C	C
300						
14	C	C	C	C	C	C
350						
16	C	C	C	C	C	C
400						
18	C	C	C	C	C	C
450						
20	C	C	C	C	C	C
500						
22	C	C	C	C	C	
550						
24	C	C	C	C	C	
600						
26	C	C	C	C		
650						
28	C	C	C	C		
700						
30	C	C	C	C		
750						
32	C	C	C			
800						
34	C	C	C			
850						
36	C	C	C			
900						
38	C	C	C			
950						
40	C	C	C			
1000						
42	C	C	C			
1050						
48	C	C	C			
1200						
56	C	C	C			
1400						

TRUNNION BALL VALVE

OVERVIEW

2-PIECE SPLIT BODY

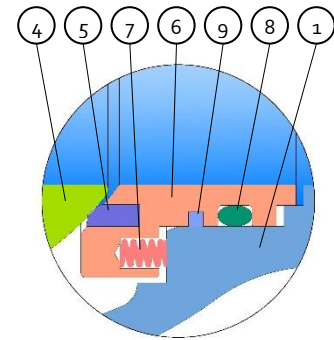
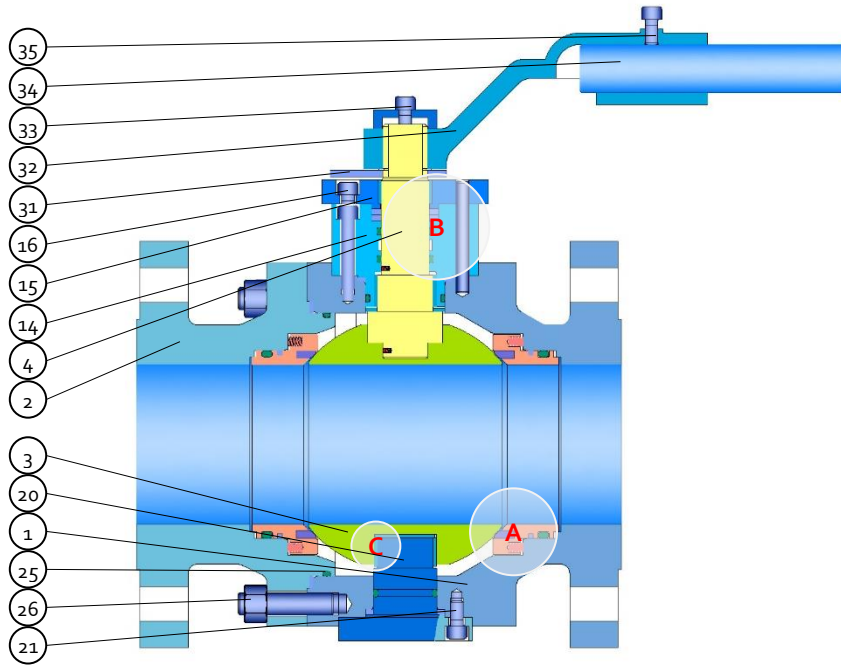

A

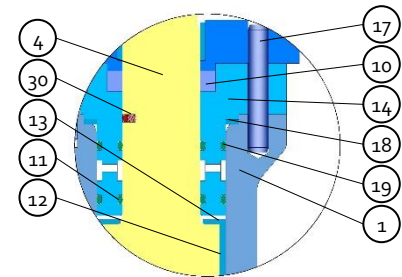

B

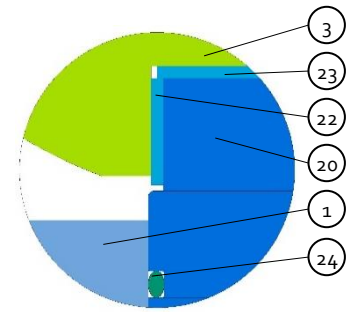

C

Forging Steel

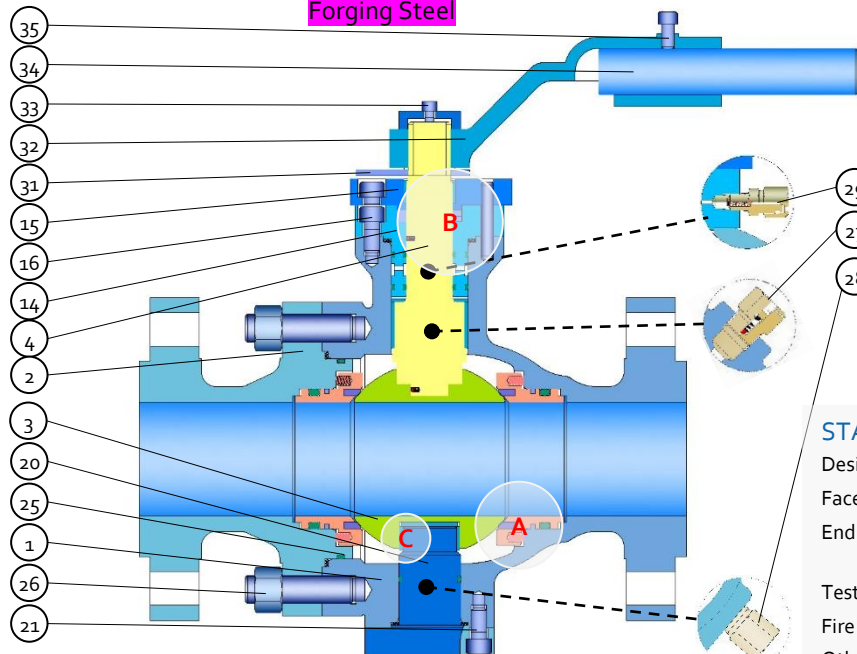

Casting Steel

STANDARDS

Design & manufacture	API 6D, ISO 14313, ISO 17292
Face-to-face	API 6D, ASME B16.10
End flanges	ASME B16.5, ASME B16.47 MSS SP-44 (NPS 22 Only)
Test & inspection	API 6D, API 598
Fire safe	API 6FA, API 607
Other	NACE MR01-75, MR 0103 ISO 15848, API 622, API 624

PART LIST

1 Body	13 Thrust washer	25 Body seal
2 Closures	14 Stuffing box	26 Stud bolt & nut
3 Ball	15 Gland cover	27 Vent valve
4 Stem	16 Gland socket bolt	28 Drain plug
5 Seat insert	17 Gland pin	29 Stem sealant valve
6 Seat retainer	18 Gland seal	30 Antistatic assembly
7 Seat spring	19 Gland O-ring	31 Stopper
8 Seat O-ring	20 Trunnion	32 Lever
9 Seat seal	21 Trunnion socket bolt	33 Lever lock screw
10 Stem packing	22 Trunnion bushing	34 Extension pipe
11 Stem O-ring	23 Trunnion thrust washer	35 Pipe lock screw
12 Stem bushing	24 Trunnion O-ring	

TYPICAL MATERIALS

Body/Closures	A105, A182 F304, F304L, F316, F316L, F51, F53, A350 LF2, LF3, LF5, Monel, Inconel, Hastelloy (Forging) A216 WCB, A351 CF3, CF8, CF3M, CF8M, A995 4A, 5A, A352 LCB, LCC, LC2 (Casting)
Ball	CS+ENP, A182 F304, F304L, F316, F316L, F51, F53, CS+TCC, CS+Ni60
Seat retainer	CS+ENP, A182 F304, F304L, F316, F316L, F51, F53, CS+TCC, CS+Ni55
Seat insert	PTFE, RPTFE, Nylon, Devlon, PEEK
Stem	A182 F6a, F316, F51, A105+ENP, AISI 4140+ENP, 17-4PH
Packing	Graphite, PTFE, RPTFE
O-ring	Viton, NBR, HNBR, AFLAS

TRUNNION BALL VALVE

OVERVIEW

3-PIECE SPLIT BODY

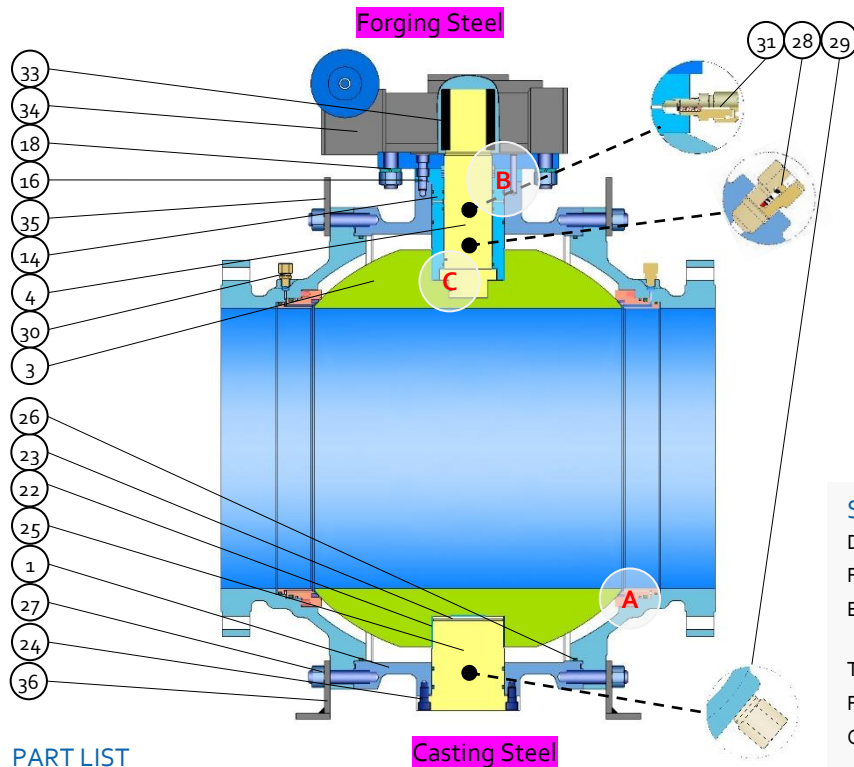
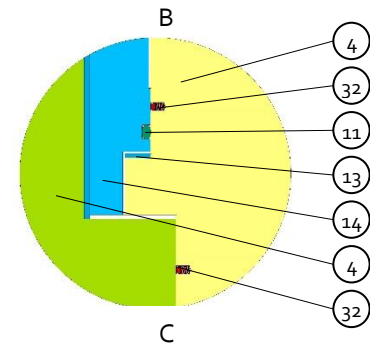
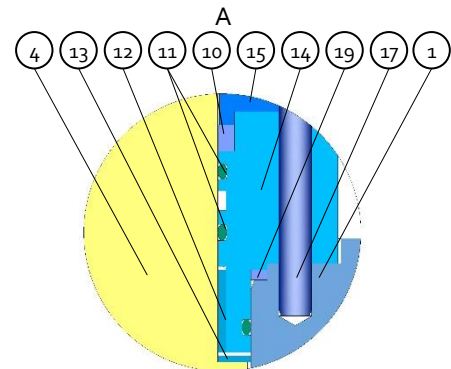
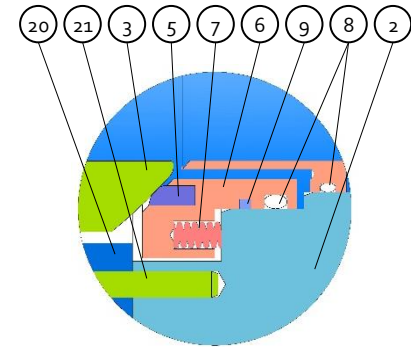
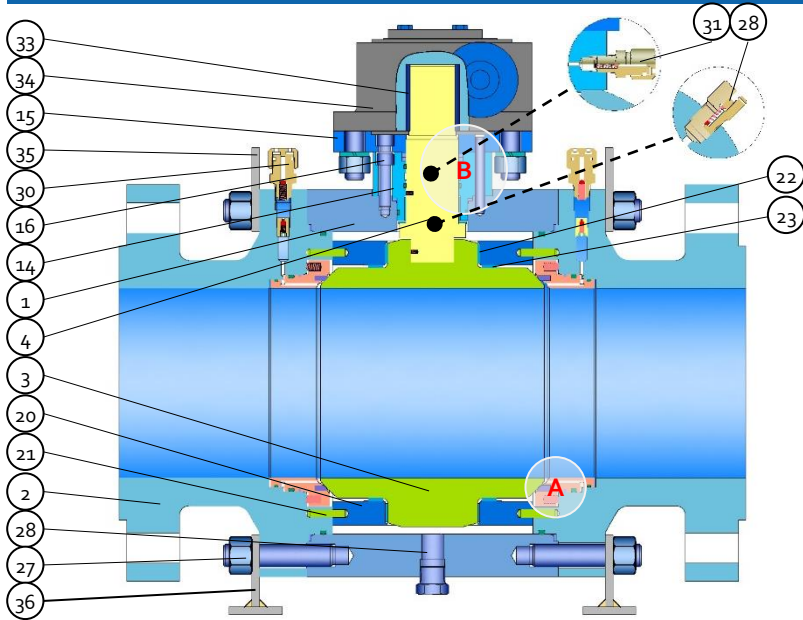

STANDARDS

Design & manufacture	API 6D, ISO 14313, ISO 17292
Face-to-face	API 6D, ASME B16.10
End flanges	ASME B16.5, ASME B16.47 MSS SP-44 (NPS 22 Only)
Test & inspection	API 6D, API 598
Fire safe	API 6FA, API 607
Other	NACE MR01-75, MR 0103 ISO 15848, API 622, API 624

PART LIST

1 Body	13 Thrust washer	25 Trunnion
2 Closures	14 Stuffing box	26 Body seal
3 Ball	15 Gland cover	27 Stud bolt & nut
4 Stem	16 Gland socket bolt	28 Vent valve
5 Seat insert	17 Gland pin	29 Drain plug
6 Seat retainer	18 Gland bolt & nut	30 Seat sealant valve
7 Seat spring	19 Gland seal	31 Stem sealant valve
8 Seat O-ring	20 Trunnion support	32 Antistatic assembly
9 Seat seal	21 Trunnion support pin	33 Drive key
10 Stem packing	22 Bushing	34 Gearbox assembly
11 Stem O-ring	23 Thrust washer	35 Lifting lug
12 Stem bushing	24 Trunnion socket bolt	36 Supporting leg

TYPICAL MATERIALS

Body/Closures	A105, A182 F304, F304L, F316, F316L, F51, F53, A350 LF2, LF3, LF5, Monel, Inconel, Hastelloy (Forging) A216 WCB, A351 CF3, CF8, CF3M, CF8M, A995 4A, 5A, A352 LCB, LCC, LC2 (Casting)
Ball	CS+ENP, A182 F304, F304L, F316, F316L, F51, F53, CS+TCC, CS+Ni60
Seat retainer	CS+ENP, A182 F304, F304L, F316, F316L, F51, F53, CS+TCC, CS+Ni55
Seat insert	PTFE, RPTFE, Nylon, Devlon, PEEK
Stem	A182 F6a, F316, F51, A105+ENP, AISI 4140+ENP, 17-4PH
Packing	Graphite, PTFE, RPTFE
O-ring	Viton, NBR, HNBR, AFLAS

TRUNNION BALL VALVE

OVERVIEW

WELDED BODY

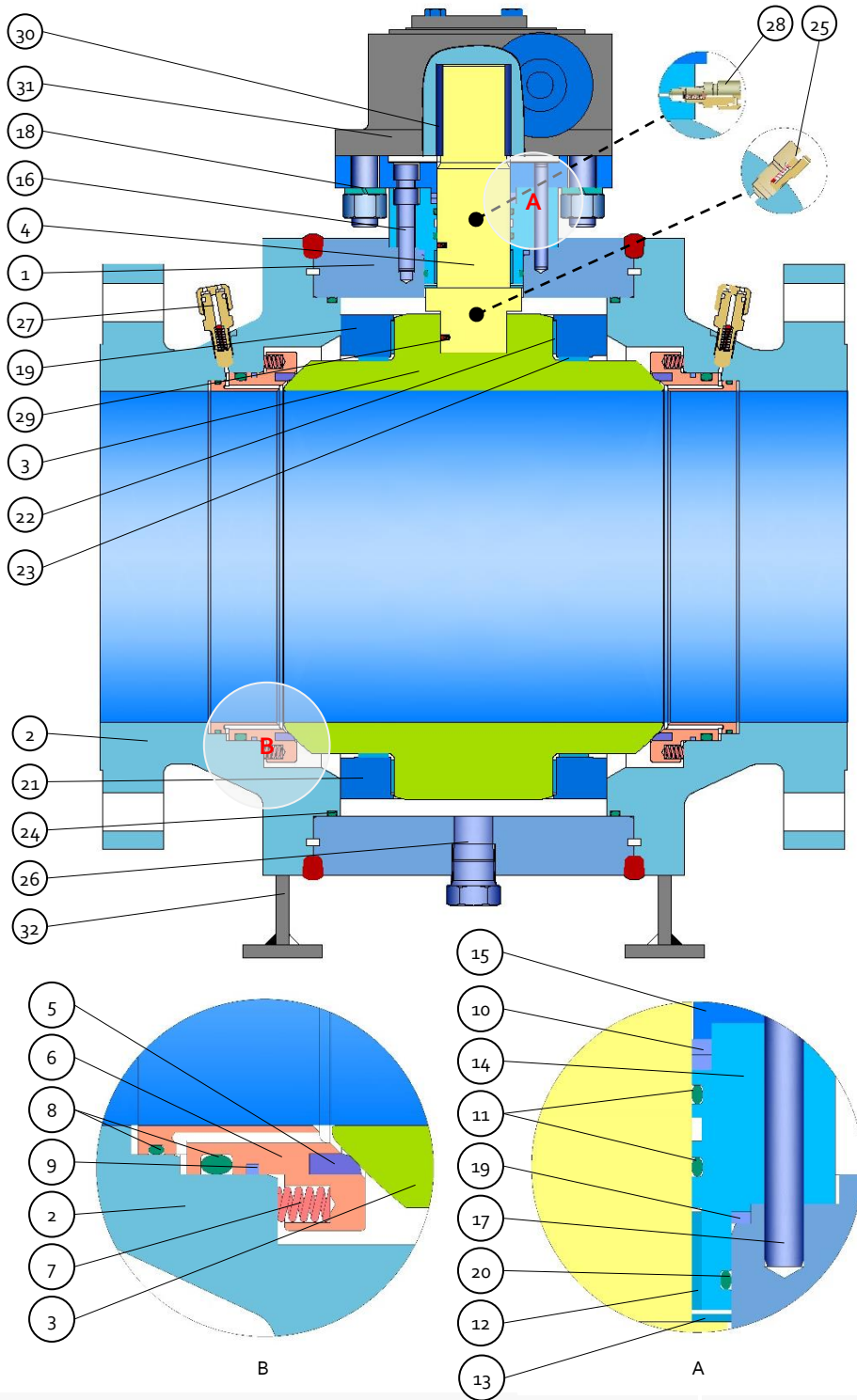

PART LIST

- 1 Body
- 2 Closures
- 3 Ball
- 4 Stem
- 5 Seat Insert
- 6 Seat retainer
- 7 Seat spring
- 8 Seat O-ring
- 9 Seat seal
- 10 Stem packing
- 11 Stem O-ring
- 12 Stem bushing
- 13 Thrust washer
- 14 Stuffing box
- 15 Gland cover
- 16 Gland socket bolt
- 17 Gland pin
- 18 Gland bolt & nut
- 19 Gland seal
- 20 Gland O-ring
- 21 Trunnion support
- 22 Trunnion support bushing
- 23 Trunnion support thrust washer
- 24 Body seal
- 25 Vent valve
- 26 Drain plug
- 27 Seat sealant valve
- 28 Stem sealant valve
- 29 Antistatic assembly
- 30 Drive key
- 31 Gearbox assembly
- 32 Supporting leg

TYPICAL MATERIALS

Body/Closures	A105, A182 F304, F304L, F316, F316L, F51, F53 A350 LF2, LF3, LF5, Monel, Inconel, Hastelloy (Forging only)
Ball	CS+ENP, A182 F304, F304L, F316, F316L, F51, F53 CS+TCC, CS+Ni60
Seat retainer	CS+ENP, A182 F304, F304L, F316, F316L, F51, F53 CS+TCC, CS+Ni55
Seat insert	PTFE, RPTFE, Nylon, Devlon, PEEK
Stem	A182 F6a, F316, F51, A105+ENP, AISI 4140+ENP, 17-4PH
Packing	Graphite, PTFE, RPTFE
O-ring	Viton. NBR. HNBR. AFLAS

STANDARDS

Design& manufacture	API 6D, ISO 14313, ISO 17292
Face-to-face	API 6D, ASME B16.10
End flanges	ASME B16.5, ASME B16.47 MSS SP-44 (NPS 22 Only)
Test & inspection	API 6D, API 598
Fire safe	API 6FA, API 607
Other	NACE MR01-75, MR 0103 ISO 15848, API 622, API 624

TRUNNION BALL VALVE

DIMENSIONS AND WEIGHTS

ASME CLASS 150 (PN 20)

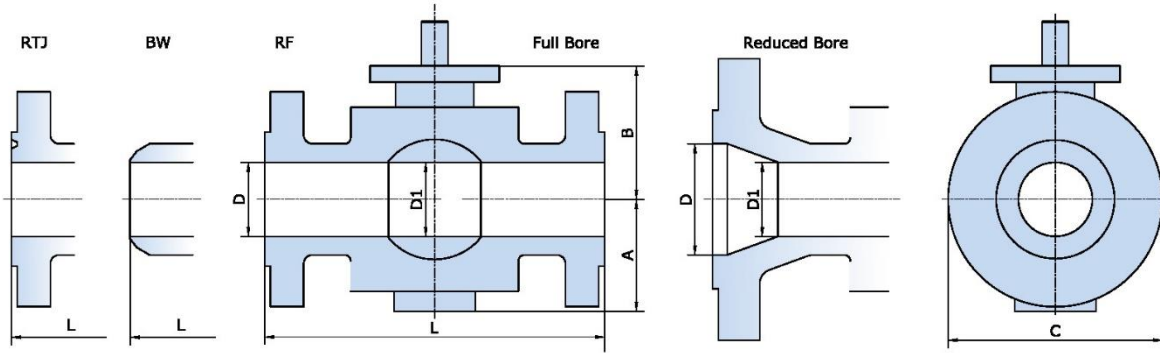

ASME CLASS 150 (PN 20) FULL BORE

Size in/mm	D	D1	L			Casting			Forging			Weight	
			RF	RTJ	BW	A	B	C	A	B	C	RF/RTJ (lb/kg)	BW (lb/kg)
2	1.93	1.93	7	7.5	8.5	3.4	5.3	5.9	3.1	4.6	5.9	40	35
50	49	49	178	191	216	86	135	150	79	117	150	18	16
2 1/2	2.44	2.44	7.5	8	9.5	3.9	5.9	7.3	3.6	5.7	7.1	53	48
65	62	62	191	203	241	100	150	185	92	145	180	24	22
3	2.91	2.91	8	8.5	11	4.9	6.3	7.8	4	5.6	7.7	73	66
80	74	74	203	216	283	125	161	198	102	141	195	33	30
4	3.94	3.94	9	9.5	12	5.2	7.5	9	4.8	6.7	9	110	99
100	100	100	229	242	305	132	190	230	123	170	230	50	45
5	5	5	14	14.53	14	6.1	8.1	11.2	5.9	7.9	11	238	224
125	127	127	356	369	356	155	205	285	150	200	280	108	102
6	5.91	5.91	15.5	16	18	7.2	9.2	12.6	6.6	8.7	12.1	319	286
150	150	150	394	407	457	184	233	320	168	222	308	145	130
8	7.91	7.91	18	18.5	20.5	9	10	15.7	9	10	15.3	562	368
200	201	201	457	470	521	228	253	398	230	255	388	255	235
10	9.92	9.92	21	21.5	22	10.6	11.4	19.1	11.2	11.8	18.7	859	811
250	252	252	533	546	559	268	290	485	285	300	475	390	368
12	11.94	11.94	24	24.5	25	12.9	15.6	22.2	13.4	14.4	21.4	1,342	1232
300	303	303	610	623	635	327	395	565	340	340	543	610	560
14	13.15	13.15	27	27.5	30	14.8	15.6	14	14.2	15	23.5	1718	1652
350	334	334	686	699	762	375	395	610	360	381	598	780	750
16	15.16	15.16	30	30.5	33	16	17.8	27.9	15.7	16.5	26.7	2640	2420
400	385	385	762	775	838	405	452	708	400	419	678	1200	1100
18	17.17	17.17	34	34.5	36	18.3	18.5	30.1	18.1	18.5	29.9	3304	3124
450	436	436	864	877	914	465	470	765	460	470	760	1500	1420
20	19.17	19.17	36	36.5	39	21.7	21.7	34.3	19.3	19.9	33.1	4207	4075
500	487	487	914	927	991	550	550	870	490	505	840	1910	1850
22	21.19	21.19	39	39.5	43	19.1	19.1	37	18.9	21.5	36.8	4928	4774
550	538	538	991	1003	1092	485	550	940	480	545	935	2240	2170
24	23.19	23.19	42	42.5	46	24	24.1	40.4	23.6	23.9	39.8	6820	6006
600	589	589	1067	1080	1143	610	612	1026	600	607	1010	3100	2730
26	24.94	24.94	45	(1)	49	24.8	26	43.7	24.5	25.6	42.5	7048	6894
650	633	633	1143	(1)	1245	630	660	1110	623	651	1080	3200	3130
28	26.94	26.94	49	(1)	53	27	28	46.3	26.8	27.2	45.6	7963	7963
700	684	684	1245	(1)	1346	685	700	1175	680	690	1157	3615	3540
30	28.94	28.94	51	(1)	55	28	30.6	49.8	29	29	48.8	11814	10780
750	735	735	1295	(1)	1397	710	777	1265	737	737	1240	5370	4900
32	30.69	30.69	54	(1)	60	30.3	30.7	45.1	30.1	30.5	52.6	13310	12716
800	779	779	1372	(1)	1524	770	780	1145	765	775	1335	6050	5780
34	32.69	32.69	58	(1)	64	31.3	30.9	45.3	30.7	30.3	44.5	15180	14146
850	830	830	1473	(1)	1626	795	785	1150	780	770	1130	6900	6430
36	34.41	34.41	60	(1)	68	35.6	34.4	58.3	33.5	33.5	57.8	18920	16720
900	874	874	1524	(1)	1727	905	875	1480	850	852	1468	8600	7600
40	38.44	38.44	70.87	(1)	70.87	37	37	66.9	36.6	36.6	64.2	24200	21340
1000	976	976	1800	(1)	1800	940	940	1700	930	930	1630	11000	9700
42	40.19	40.19	74.8	(1)	74.8	38.4	38.4	66.9	37.4	37.94	66.5	31900	24816
1050	1010	1010	1900	(1)	1900	975	975	1700	950	950	1690	14500	11280
48	45.94	45.94	82.68	(1)	82.68	42.7	45.3	76.4	42.3	43.3	76	39600	35420
1200	1166	1166	2100	(1)	2100	1085	1150	1940	1075	1100	1930	18000	16100
56	53.56	53.56	94.49	(1)	94.49	50.4	51.6	90.2	50	51.6	89.6	61600	55660
1400	1360	1360	2400	(1)	2400	1280	1310	2290	1270	1310	2275	28000	25300

(1) Contact our sales representative for more information.

TRUNNION BALL VALVE

DIMENSIONS AND WEIGHTS

ASME CLASS 150 (PN 20)

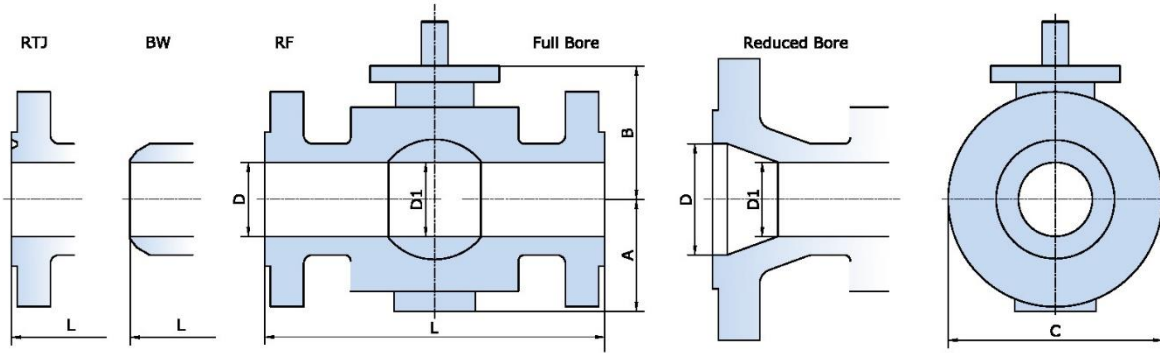

ASME CLASS 150 (PN 20) REDUCED BORE

Size in/mm	D	D1	L			Casting			Forging			Weight	
			RF	RTJ	BW	A	B	C	A	B	C	RF/RTJ (lb/kg)	BW (lb/kg)
2x1 1/2 50x40	1.93 49	1.5 38	7 178	7.5 191	8.5 216	3.3 85	4.9 125	5.9 150	3 75	4.3 110	5.9 150	33 15	26 12
2 1/2x2 65x50	2.44 62	1.93 49	7.5 190	8 203	9.5 241	3.3 86	5.3 135	7.1 180	3.1 79	4.6 117	7.1 180	49 22	42 19
3x2 80x50	2.94 74	1.93 49	8 203	8.5 216	11.13 283	3.3 86	5.3 135	7.5 190	3.1 79	4.6 117	7.5 190	68 31	48 22
4x3 100x80	3.94 100	2.94 74	9 229	9.5 241	12 305	4.9 125	9.1 230	7.8 198	4 102	5.5 141	9.1 230	97 44	81 37
6x4 150x100	5.94 150	3.94 100	15.5 394	16 406	18 457	5.5 140	7.5 190	11 280	4.8 123	6.7 170	11 280	264 120	209 95
8x6 200x150	7.94 201	5.94 150	18 457	18.5 470	20.5 521	7.2 184	9.2 233	13.6 345	6.8 172.5	8.7 222	13.6 345	463 210	414 188
10x8 250x200	9.94 252	7.94 201	21 533	21.5 546	22 559	9 228	10 253	1.6 405	9.1 230	10 255	15.9 405	728 330	671 305
12x10 300x250	11.94 303	9.94 252	24 610	24.5 622	25 635	10.6 268	11.4 290	19.1 485	11.2 285	11.8 300	19.1 485	1123 510	925 420
14x10 350x250	13.19 334	9.94 252	27 686	27.5 699	30 762	10.6 268	11.4 290	21 535	11.2 285	11.8 300	21 535	1542 700	1211 550
16x12 400x300	15.19 385	11.94 303	30 762	30.5 775	33 838	12.9 327	15.6 395	22.2 565	13.4 340	13.4 340	23.4 595	2004 910	1674 760
18x14 450x350	17.19 436	13.19 334	34 864	34.5 877	36 914	14.8 375	15.6 395	25 635	14.2 360	15 381	25 635	2974 1350	2600 1180
20x16 500x400	19.19 487	15.19 385	36 914	36.5 927	39 991	15.9 405	17.8 452	27.9 708	15.7 400	21.7 419	27.6 700	3722 1690	3304 1500
24x20 600x500	23.19 589	19.19 487	42 1067	42.5 1080	45 1143	21.7 550	21.7 550	34.3 870	19.3 490	19.9 505	33.1 840	5352 2430	4780 2170
30x24 750x600	28.94 735	23.19 589	51 1295	(1) 1397	55 1397	24 610	24.1 612	40.4 1026	23.6 600	23.9 607	39.8 1010	9097 4130	8150 3700
36x30 900x750	34.44 874	28.94 735	60 1524	(1) 1727	68 1727	28 710	30.6 777	49.8 1265	29 737	29 737	48.8 1240	16300 74100	14978 6800

(1) Contact our sales representative for more information.

TRUNNION BALL VALVE

DIMENSIONS AND WEIGHTS

ASME CLASS 300 (PN 50)

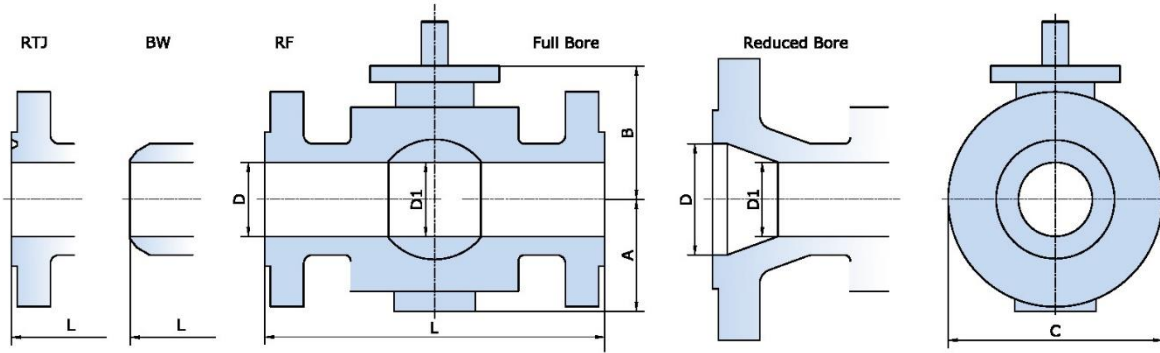

ASME CLASS 300 (PN 50) FULL BORE

Size in/mm	D	D1	L			Casting			Forging			Weight	
			RF	RTJ	BW	A	B	C	A	B	C	RF/RTJ (lb/kg)	BW (lb/kg)
2	1.93	1.93	8.5	9.13	8.5	3.6	5.3	6.5	3.3	4.6	6.5	62	51
50	49	49	216	232	216	91	135	165	83	117	165	28	23
2 1/2	2.44	2.44	9.5	10.12	9.5	3.7	5.9	7.3	3.6	5.7	7.1	77	73
65	62	62	241	257	241	95	150	185	92	145	180	35	33
3	2.94	2.94	11.13	11.75	11.13	5	6.3	8.3	4.1	5.6	8.3	95	88
80	74	74	282	298	283	126	161	210	105	141	210	43	40
4	3.94	3.94	12	12.63	12	5.2	7.5	10	5	6.7	10	152	143
100	100	100	305	321	305	132	190	255	128	170	255	69	65
5	5	5	15.75	16.26	15.75	6.3	8.3	11.6	6.1	8	11.2	328	304
125	125	125	400	413	400	160	210	295	155	202	285	149	138
6	5.94	5.94	15.88	16.5	18	7.4	9.2	13	6.6	8.7	12.6	396	308
150	150	150	403	419	457	189	233	330	168	222	320	180	140
8	7.91	7.91	19.75	20.38	20.5	9	10	15.7	9.3	10	15.4	647	539
200	201	201	502	518	521	228	253	398	235	255	392	294	245
10	9.92	9.92	22.38	23	22	10.6	11.4	10.1	11.4	12	19.1	976	903
250	252	252	568	584	559	268	290	485	290	305	485	443	410
12	11.94	11.94	25.5	28.13	25.5	12.9	15.6	23.2	13.4	13.4	21.8	1542	1432
300	303	303	648	664	635	327	395	590	340	340	554	700	650
14	13.19	13.19	30	30.62	30	15.2	15.7	24.8	14.5	15	23.9	2042	1949
350	334	334	762	778	762	385	400	630	368	384	606	927	885
16	15.19	15.19	33	33.63	33	15.9	17.8	28.2	16.5	16.5	27.1	2863	2731
400	385	385	838	854	838	405	452	716	420	419	689	1300	1240
18	17.19	17.19	36	36.63	36	18.9	19.3	31.5	18.5	18.9	30.7	3744	3480
450	436	436	914	930	914	480	490	800	470	480	780	1700	1580
20	19.17	19.17	39	39.75	39	21.7	21.7	34.3	19.5	19.9	33.5	5066	4405
500	487	487	991	1010	991	550	550	870	495	505	850	23000	2000
22	21.19	21.19	43	43.88	43	20.3	21.7	37.8	20.1	21.5	37.2	5390	4840
550	538	538	1092	1114	1092	515	550	960	510	545	945	2450	2200
24	23.19	23.19	45	45.888	45	24	24.8	40.6	24.8	23.9	40.9	8436	7600
600	589	589	1143	1165	1143	610	630	1030	630	607	1038	3830	3450
26	24.94	24.94	49	50	49	28.4	26	43.1	24.5	25.6	42.7	9295	8480
650	633	633	1245	1270	1245	630	660	1095	623	651	1085	4220	3850
28	26.94	26.94	53	54	53	27.6	28	46.9	27.2	27.6	46.3	10604	9372
700	684	684	1346	1372	1346	700	710	1190	690	700	1175	4820	4260
30	28.94	28.94	55	56	55	28	30.6	49.8	29.4	29.4	49.8	12320	11330
750	735	735	1397	1422	1397	710	777	1265	747	747	1266	5600	5150
32	30.69	30.69	60	61.13	60	30.7	31.1	53.1	30.3	30.7	53	15088	13767
800	779	779	1524	1552	1524	780	790	1350	770	780	1345	6850	6250
34	32.69	32.69	64	65.1	64	31.9	30.5	47.8	31.9	30.5	47.8	15510	14190
850	830	830	1626	1654	1626	810	775	1215	810	775	1215	7050	6450
36	34.41	34.41	68	69.13	68	35.6	34.4	58.3	34	34	58.7	19800	18480
900	874	874	1727	1756	1727	905	875	1480	864	864	1492	9000	8400
40	38.44	38.44	76.77	(1)	76.77	37	37	65	36.6	36.6	64.6	24200	22660
1000	976	976	1950	(1)	1950	940	940	1650	930	930	1640	11000	10300
42	40.19	40.19	82.68	(1)	82.68	38.2	38.2	66.9	37.8	37.8	66.5	31900	29920
1050	1020	1020	2100	(1)	2100	970	970	1700	960	960	1690	14500	13600
48	45.94	45.94	85.43	(1)	85.43	44.1	44.1	77.4	43.3	43.3	76.6	39600	37620
1200	1166	1166	2170	(1)	2170	1120	1120	1965	1100	1100	1945	18000	17100
56	53.56	53.56	98.43	(1)	98.43	50.4	53.1	90.4	50	52.2	89.8	60060	56760
1400	1360	1360	2500	(1)	2500	1280	1350	2295	1270	1325	2282	27300	25800

(1) Contact our sales representative for more information.

TRUNNION BALL VALVE

DIMENSIONS AND WEIGHTS

ASME CLASS 300 (PN 50)

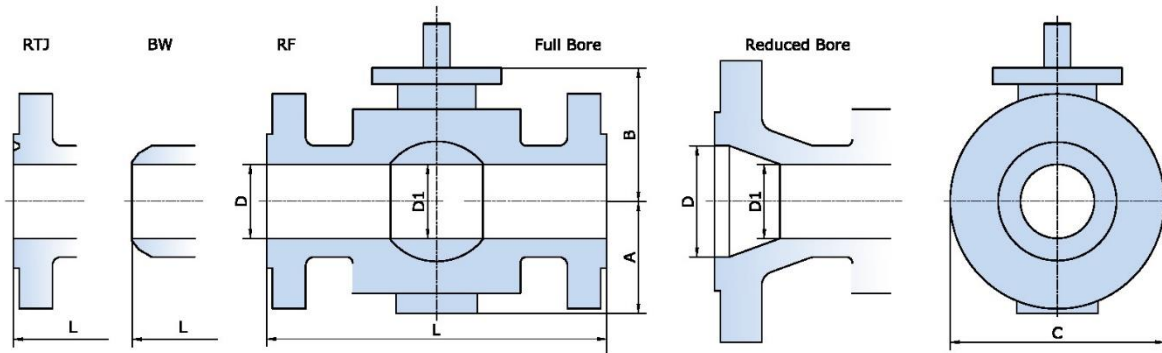

ASME CLASS 300 (PN 50) REDUCED BORE

Size in/mm	D	D1	L			Casting			Forging			Weight	
			RF	RTJ	BW	A	B	C	A	B	C	RF/RTJ (lb/kg)	BW (lb/kg)
2x1 1/2 50x40	1.93 49	1.5 38	8.5 216	9.11 232	8.5 216	3.5 90	5.1 130	6.5 165	3.3 83	4.3 110	6.5 165	48 22	41 18.5
2 1/2x2 65x50	2.44 62	1.93 49	9.5 241	10.13 257	9.5 241	3.6 91	5.3 135	6.5 165	3.3 83	4.6 117	7.5 190	62 28	55 25
3x2 80x50	2.94 74	1.93 49	11.13 283	11.75 298	11.13 283	3.6 91	5.3 135	8.3 210	3.3 83	4.6 117	8.3 210	81 37	75 34
4x3 100x80	3.94 100	2.94 74	12 305	12.63 321	12 305	5 128	6.3 161	10 255	5 128	5.6 141	10 255	119 54	90 41
6x4 150x100	5.94 150	3.94 100	15.88 403	16.5 419	18 457	6.3 160	7.5 190	12.6 320	6.3 160	6.7 170	12.6 320	242 110	187 85
8x6 200x150	7.94 201	5.94 150	19.75 518	20.38 518	20.5 521	7.5 190	9.2 233	15 380	7.5 190	8.7 222	15 380	495 225	451 205
10x8 250x200	9.94 252	7.94 201	22.38 568	23 584	22 559	9 228	10 253	17.5 445	9.3 235	10 255	17.5 445	803 365	748 340
12x10 300x250	11.94 303	9.94 252	25.5 648	26.13 664	25 635	10.6 268	11.4 290	20.5 520	11.4 290	12 305	20.5 520	1320 600	1239 563
14x10 350x250	13.19 334	9.94 252	30 762	30.63 778	30 762	10.6 268	11.4 290	23 585	11.4 290	12 305	23 585	1762 800	1432 650
16x12 400x300	15.19 385	11.94 334	33 838	33.63 854	33 838	12.9 327	15.6 395	23.2 590	13.4 340	13.4 340	21.8 554	2445 1110	2269 1030
18x14 450x350	17.19 436	13.19 334	36 914	36.62 930	36 914	15.2 385	15.7 400	28 710	14.5 368	15.1 384	28 710	3300 1500	3102 1410
20x16 500x400	19.19 487	15.19 385	39 991	49.75 1010	39 991	16 405	17.8 452	28.2 716	16.5 420	16.5 419	27.1 689	4626 2100	4185 1900
24x20 600x500	23.19 589	19.19 487	45 1143	45.88 1165	45 1143	21.7 550	21.7 550	36 915	19.5 495	19.9 505	36 915	6057 2750	5617 2550
30x24 750x600	28.94 735	23.19 589	55 1397	56 1422	55 1397	24 610	24.8 630	42.9 1090	24.85 630	23.9 607	42.9 1090	9350 4250	8492 3860
36x30 900x750	34.44 874	28.94 735	55 1397	56 1422	55 1397	28 710	30.6 777	50 1270	29.4 747	29.4 747	50 1270	16740 7600	14450 6560

(1) Contact our sales representative for more information.

TRUNNION BALL VALVE

DIMENSIONS AND WEIGHTS

ASME CLASS 600 (PN 100)

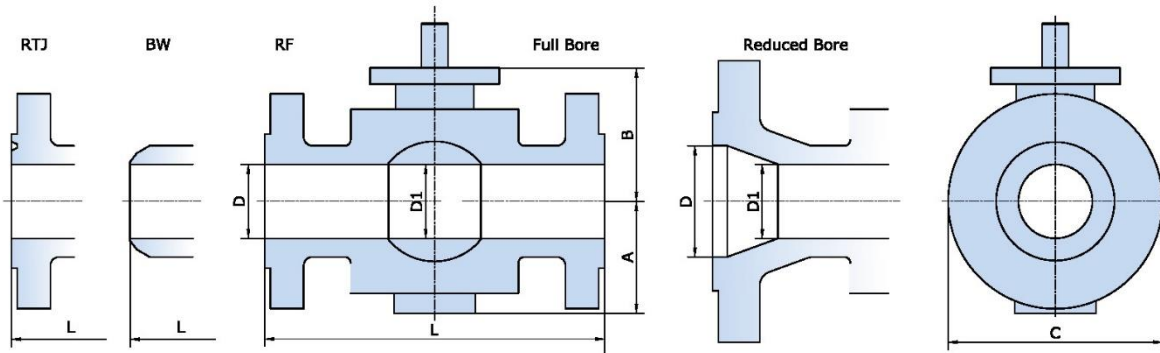

ASME CLASS 600 (PN 100) FULL BORE

Size in/mm	D	D1	L			Casting			Forging			Weight	
			RF	RTJ	BW	A	B	C	A	B	C	RF/RTJ (lb/ka)	BW (lb/ka)
2	1.93	1.93	11.5	11.63	11.5	3.7	5.7	6.5	3.3	5	6.5	62	57
50	49	49	292	295	292	95	145	165	83	126	165	28	26
2 1/2	2.44	2.44	13	13.13	13	3.9	6.3	7.7	3.7	5.9	7.4	119	106
65	62	62	330	333	330	100	160	195	95	150	188	54	48
3	2.94	2.94	14	14.13	14	5	7.2	8.3	4.6	6.1	8.3	165	159
80	74	74	356	359	356	128	184	210	117	155	210	75	72
4	3.94	3.94	17	17.13	17	5.8	8.2	11.6	5.4	7	10.8	242	209
100	100	100	432	435	432	148	209	295	138	177	275	110	95
5	5	5	20	20.12	20	6.7	8.2	13.4	6.5	8	13	407	352
125	127	125	508	511	508	170	208	340	165	202	330	185	160
6	5.94	5.94	22	22.13	22	7.7	9.8	14	7	9	14	551	511
150	150	150	559	562	559	195	250	355	178	228	355	250	232
8	7.91	7.91	26	26.13	26	9.6	11.1	16.5	9.6	10.5	16.5	914	727
200	201	201	660	663	660	245	283	420	265	267	420	415	330
10	9.92	9.92	31	31.13	31	11.4	12.6	20	11.9	12.3	20	1652	1564
250	252	252	787	790	787	290	320	510	302	312	510	750	710
12	11.94	11.94	33	33.13	33	14.2	15.3	22.8	13.8	14.5	22.6	2024	1808
300	303	303	838	841	835	360	390	580	350	368	573	919	820
14	13.19	13.19	35	35.12	35	15.6	16.1	25	15	15.6	24.8	2863	2445
350	334	334	889	891	889	395	410	635	380	396	630	1300	1110
16	15.19	15.19	39	39.13	39	16.7	17.2	28.3	17.3	17.5	16.7	3722	33304
400	385	385	991	994	991	425	436	720	440	444	423	1690	1500
18	17.19	17.19	43	43.13	43	19.3	20.3	32.3	18.9	20	31.9	5176	4670
450	436	435	1092	1095	1092	490	515	820	480	510	810	2350	2120
20	19.17	19.17	47	47.25	47	22.6	22.7	36.2	20.6	20.7	34.4	6500	6013
500	487	487	1194	1200	1194	575	576	920	522	525	875	2950	2730
22	21.19	21.19	51	51.38	51	20.5	22	37.8	20.3	26.7	37.4	6938	6432
550	538	538	1295	1305	1295	520	560	960	515	550	950	3150	2920
24	23.19	23.19	55	55.38	55	23.8	25.2	41	24.4	25.2	41.3	10573	9692
600	589	589	1397	1407	1397	605	640	1043	619	641	1050	4800	4400
26	24.94	24.94	57	57.5	57	25.6	26.4	43.9	25.5	26.2	43.3	11718	10683
650	633	633	1448	1461	1448	650	670	1115	640	665	1100	5320	4850
28	26.94	26.94	61	61.5	61	26.8	23.3	48	26.6	28.1	47.6	17400	16410
700	684	684	1549	1562	1594	680	720	1220	675	715	1210	7900	7450
30	28.94	28.94	65	65.5	65	29.9	30.6	51.8	29.1	30.6	51	19600	18612
750	735	735	1651	1664	1651	760	777	1315	740	776	1295	8900	8450
32	30.69	30.69	70	70	70.63	31.1	31.5	55.5	30.9	31.3	53.9	20240	18260
800	779	779	1778	1778	1794	790	790	1410	785	794	1370	9200	8300
34	32.69	32.69	76	76.61	76	33.1	33.9	56.3	32.7	33.5	57.5	29295	25300
850	830	830	1930	1946	1930	840	860	1480	830	850	1460	13300	11500
36	34.41	34.41	82	82.63	82	35	36.6	60.9	35.4	36.2	60.9	30176	27533
900	874	874	2083	2099	2083	890	930	1546	900	920	1548	13700	12500
40	38.44	38.44	80.71	(1)	80.71	37.8	38	65.6	37.4	37.6	65.2	31460	29172
1000	976	976	2050	(1)	2050	960	965	1665	950	955	1655	14300	13260
42	40.19	40.19	82.68	(1)	82.68	40.9	41.7	72.8	40.6	41.3	71.7	36080	33660
1050	1020	1020	2100	(1)	2100	1040	1060	1850	1030	1050	1820	16400	15300
48	45.94	45.94	94.49	(1)	94.49	46.9	46.3	78.3	46.5	45.9	77.6	49940	46200
1200	1166	1166	2400	(1)	2400	1190	1175	1990	1180	1165	1970	22700	21000
56	53.56	53.56	106.3	(1)	106.3	54.5	54.3	93.5	54.2	53.5	92.6	81400	30800
1400	1360	1360	2700	(1)	2700	1385	1380	2375	1376	1360	2352	37000	14000

(1) Contact our sales representative for more information.

TRUNNION BALL VALVE

DIMENSIONS AND WEIGHTS

ASME CLASS 600 (PN 100)

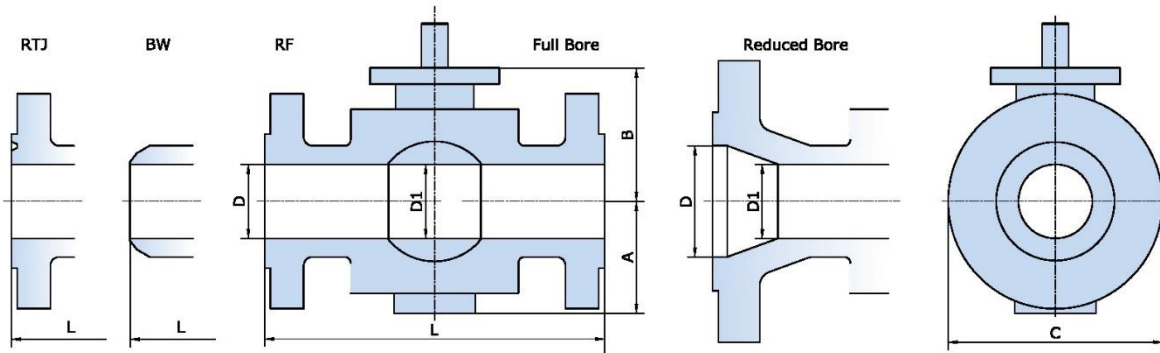

ASME CLASS 600 (PN 100) REDUCED BORE

Size in/mm	D	D1	L			Casting			Forging			Weight	
			RF	RTJ	BW	A	B	C	A	B	C	RF/RTJ (lb/kg)	BW (lb/kg)
2x1 1/2	1.93	1.5	11.5	11.62	11.5	3.7	5.28	6.5	3.3	4.5	6.5	53	46
50x40	49	38	292	295	292	94	134	165	83	115	165	24	21
2 1/2x2	2.44	1.93	13	13.13	13	3.7	5.7	7.5	3.3	5	7.5	95	64
65x50	62	49	330	333	330	95	145	190	83	126	190	43	29
3x2	2.94	1.93	14	14.13	14	3.7	5.7	8.3	3.3	5	8.3	93	86
80x50	74	49	356	359	356	95	145	210	83	126	210	42	39
4x3	3.94	2.94	17	17.13	17	5.4	7.2	10.8	5.5	6.1	10.8	187	150
100x80	100	74	432	435	432	138	184	275	138	155	275	85	68
6x4	5.94	3.94	22	22.13	22	7	8.2	14	7	7	14	330	187
150x100	150	100	559	562	559	178	208	355	178	177	355	150	85
8x6	7.94	5.94	26	26.13	26	8.3	9.8	16.5	8.3	9	16.5	638	528
200x150	201	150	660	663	660	210	250	420	210	228	420	290	240
10x8	9.94	7.94	31	31.13	31	9.6	11.1	20	9.6	10.5	20	1256	1167
250x200	252	201	787	790	787	245	283	510	245	267	510	570	530
12x10	11.94	9.94	33	33.13	33	11.4	12.6	22	11.9	12.3	22	1762	1608
300x250	303	252	838	841	838	290	320	560	302	312	560	800	730
14x10	13.19	9.94	35	35.13	35	11.4	12.6	23.8	11.9	12.3	23.8	2489	2247
350x250	334	252	889	892	889	290	320	605	302	312	605	1130	1020
16x12	15.19	11.94	39	39.13	39	14.1	15.4	27	13.8	14.5	27	3414	2930
400x300	385	303	991	994	991	360	390	685	350	368	685	1550	1330
18x14	17.19	13.19	43	43.13	43	15.6	16.1	29.3	15.2	15.6	29.3	4405	3965
450x350	436	334	1092	1095	1092	395	410	745	385	396	745	2000	1800
20x16	19.19	15.19	47	47.25	47	16.7	17.2	32	17.3	17.5	32.1	5727	5286
500x400	487	385	1194	1200	1194	425	436	815	440	444	815	2600	2400
24x20	23.19	19.19	55	55.38	55	22.6	22.7	37	20.6	20.7	37	6500	7819
600x500	589	487	1397	1407	1397	575	576	940	522	525	940	3950	3550
30x24	28.94	23.19	61	65.5	65	23.8	25.2	42.9	24.4	25.2	42.9	18722	17621
750x600	735	589	1651	1664	1651	605	640	1090	619	641	1090	8500	8000
36x30	34.41	28.94	82	82.63	82	35	36.6	60.9	35.4	36.2	60.9	23965	20925
900x750	874	735	2083	2099	2083	890	930	1546	900	920	1548	10880	9500

(1) Contact our sales representative for more information.

TRUNNION BALL VALVE

DIMENSIONS AND WEIGHTS

ASME CLASS 900 (PN 150)

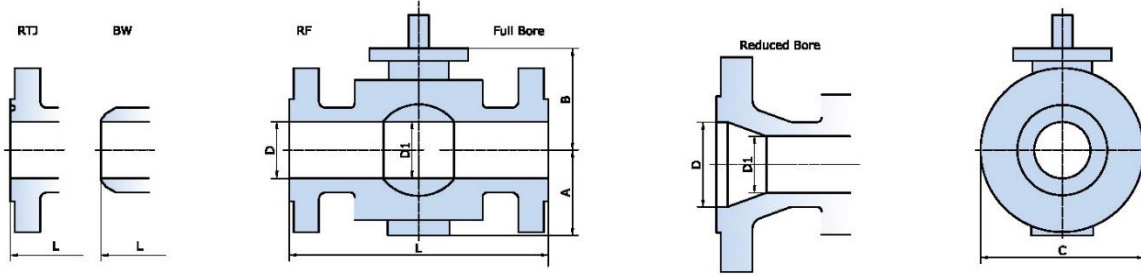

ASME CLASS 900 (PN 150) FULL BORE

Size in/mm	D	D1	L			Casting			Forging			Weight	
			RF	RTJ	BW	A	B	C	A	B	C	RF/RTJ (lb/kg)	BW (lb/kg)
2	1.93	1.93	14.5	14.63	14.5	4.3	5.5	8.5	4.3	5.5	8.5	128	119
50	49	49	368	371	368	108	140	215	108	140	215	58	54
2 1/2	2.44	2.44	16.5	16.62	16.5	4.8	6.3	9.6	4.8	6.3	9.6	152	139
65	62	62	419	422	419	123	160	245	123	160	245	69	63
3	2.94	2.94	15	15.13	15	4.7	6.3	9.4	4.7	6.3	9.4	198	187
80	74	74	381	384	381	120	161	240	120	161	240	90	85
4	3.94	3.94	18	18.13	18	5.7	7.1	11.4	5.7	7.1	11.4	295	253
100	100	100	457	460	457	145	180	290	145	180	290	134	115
5	4.76	4.76	22	22.13	22	6.7	8.5	13.8	6.7	8.5	13.8	517	429
125	121	121	559	562	559	170	215	350	170	215	350	235	195
6	5.94	5.94	24	24.13	24	7.3	9.4	15	7.3	9.4	15	661	617
150	150	150	610	613	610	185	239	380	185	239	380	300	280
8	7.94	7.94	29	29.13	29	7.7	11.3	18.5	7.7	11.3	18.5	1196	1123
200	201	201	737	740	737	295	288	470	295	288	470	543	510
10	9.94	9.94	33	33.13	33	13.8	13.8	21.5	13.8	13.8	21.5	2115	1872
250	252	252	838	841	838	350	350	545	350	350	545	960	850
12	11.94	11.94	38	38.13	38	14.6	15.3	24	14.6	15.3	24	3062	2863
300	303	303	965	968	965	370	388	610	370	388	610	1390	1300
14	12.69	12.69	40.5	40.88	40.5	16.9	16.9	26.2	16.1	16.1	25.9	3414	2930
350	322	322	1029	1039	1029	430	430	665	410	410	658	1550	1330
16	14.69	14.69	44.5	44.88	44.5	17.7	18.1	29.5	17.7	18.1	29.5	4092	3190
400	373	373	1130	1140	1130	450	460	750	450	460	750	1860	1450
18	16.69	16.69	48	48.5	48	19.3	20.9	32.3	19.3	20.9	32.3	5841	5220
450	423	423	1219	1232	1219	490	530	820	490	530	820	2655	2370
20	18.56	18.56	52	52.5	52	23.2	22.2	36.5	23.2	22.2	36.5	7379	6828
500	471	471	1321	1334	1321	590	565	928	590	565	928	3500	3100
24	22.44	22.44	61	61.75	61	24.8	24.2	41.7	24.8	24.2	41.7	14053	13436
600	570	570	1549	1568	1549	630	615	1060	630	615	1060	6380	6100
26	24.31	24.31	65	65.88	(1)	26.8	27.6	45.7	26.8	27.6	45.7	14850	11968
650	617	617	1651	1673	(1)	680	700	1160	680	700	1160	6750	5440
28	26.19	26.19	69	69.88	(1)	29.3	29.5	50.6	29.3	29.5	50.6	19250	16390
700	665	665	1753	1775	(1)	743	750	1285	743	750	1285	8750	7450
30	28.06	28.06	74	74.88	(1)	31.5	31.5	53.5	31.5	31.5	53.5	25300	21340
750	712	712	1880	1902	(1)	800	800	1360	800	800	1360	11500	9700

ASME CLASS 900 (PN 150) REDUCED BORE

Size in/mm	D	D1	L			Casting			Forging			Weight	
			RF	RTJ	BW	A	B	C	A	B	C	RF/RTJ (lb/kg)	BW (lb/kg)
2x1 1/2	1.93	1.5	14.5	14.62	14.5	4.3	4.5	8.5	4.3	4.5	8.5	99	88
50x40	49	38	215	371	368	108	115	215	108	115	215	45	40
2 1/2x2	2.44	1.93	16.5	16.63	16.5	4.3	5.1	9.6	4.3	5.1	9.6	128	115
65x50	62	49	419	422	419	108	140	245	108	140	245	58	52
3x2	2.94	1.93	15	15.13	15	4.3	5.1	9.4	4.3	5.1	9.4	163	110
80x50	74	49	381	384	381	108	140	240	108	140	240	74	50
4x3	3.94	2.94	18	18.13	18	5.7	6.3	11.4	5.7	6.3	11.4	264	220
100x80	100	74	457	460	457	145	161	290	145	161	290	120	100
6x4	5.94	3.94	24	24.13	24	7.5	7.1	15	7.5	7.1	15	471	436
150x100	150	100	610	613	610	190	180	380	190	180	380	214	198
8x6	7.94	5.94	29	29.13	29	9.3	9.4	18.5	9.3	9.4	18.5	817	771
200x150	201	150	737	740	737	235	239	470	235	239	470	371	350
10x8	9.94	7.94	33	33.13	33	11.3	11.3	21.5	11.3	11.3	21.5	1542	1366
250x200	252	201	838	841	838	295	288	545	295	288	545	700	620
12x10	11.94	9.94	38	38.13	38	13	13.8	24	13	13.8	24	2643	1936
300x250	303	252	965	968	965	330	350	610	330	350	610	1200	880
14x10	14.69	11.94	44.5	44.88	44.5	14.6	15.3	24	14.6	15.3	24	2974	2467
350x250	322	303	1130	1140	1130	370	388	610	370	388	610	1350	1120
16x12	14.69	11.94	44.5	44.88	44.5	14.6	15.6	24	14.6	15.6	24	3855	3729
400x300	373	303	1130	1140	1130	370	388	610	370	388	610	1750	1720
18x14	16.69	12.69	48	48.5	48	16.9	16.9	30.9	16.1	16.1	30.9	5286	4956
450x350	423	322	1219	1232	1219	430	430	785	410	410	785	2400	2250
20x16	18.56	14.69	52	52.5	52	17.7	18.1	33.7	17.7	18.1	33.7	6993	6388
500x400	471	373	1321	1334	1321	450	460	855	450	460	855	3175	2900
24x20	22.44	18.56	61	61.75	61	23.2	22.2	40.9	23.2	22.2	40.9	11650	10793
600x500	570	471	1549	1568	1549	590	565	1040	590	565	1040	5289	4900
30x24	28.06	22.44	74	74.88	(1)	24.8	24.2	48.4	24.8	24.2	48.4	(1)	(1)
750x600	712	570	1880	1902	(1)	630	615	1230	630	615	1230	(1)	(1)

(1) Contact our sales representative for more information.

TRUNNION BALL VALVE

DIMENSIONS AND WEIGHTS

ASME CLASS 1500 (PN 250)

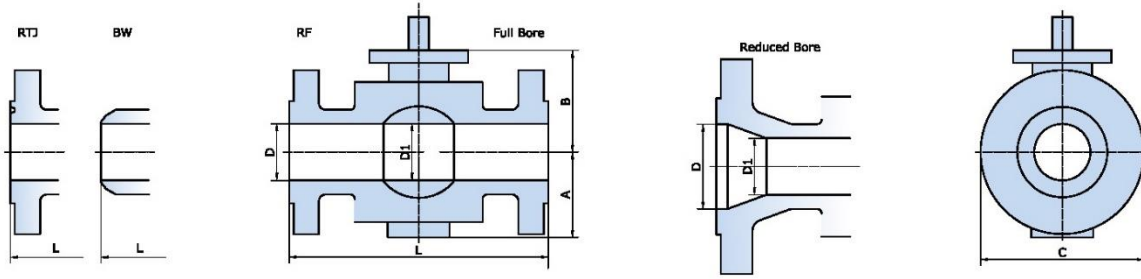

ASME CLASS 1500 (PN 250) FULL BORE

Size in/mm	D	D1	L			Casting			Forging			Weight	
			RF	RTJ	BW	A	B	C	A	B	C	RF/RTJ (lb/kg)	BW (lb/kg)
2	1.93	1.93	14.5	14.63	14.5	4.3	5.5	8.5	4.3	5.5	8.5	128	97
50	49	49	368	371	368	108	140	215	108	140	215	58	44
2 1/2	2.44	2.44	16.5	16.62	16.5	4.8	6.3	9.6	4.8	6.3	9.6	176	165
65	62	62	419	422	419	123	160	245	123	160	245	80	75
3	2.94	2.94	18.5	18.63	18.5	5.5	7.4	10.4	5.5	7.4	10.4	333	274
80	74	74	470	473	470	140	187	265	140	187	265	151	135
4	3.94	3.94	21.5	21.63	21.5	6.5	7.9	12.2	6.5	7.9	12.2	441	414
100	100	100	546	549	546	165	201	310	165	201	310	200	188
5	4.37	4.37	26.5	27.04	26.5	6.9	8.7	14.8	6.9	8.7	14.8	847	642
125	111	111	673	676	673	175	220	375	175	220	375	385	292
6	5.69	5.69	27.75	28	27.75	9.6	11.3	16.3	9.6	11.3	16.3	1123	1057
150	144	144	705	711	705	219	288	415	219	288	415	510	480
8	7.56	7.56	32.75	33.13	32.75	11.6	12.8	19.1	11.6	12.8	19.1	1804	1608
200	192	192	832	842	832	295	325	485	295	325	485	819	730
10	9.44	9.44	39	39.38	39	14.2	15.9	23.6	14.2	15.9	23.6	3282	2753
250	239	239	991	1001	991	360	405	600	360	405	600	1490	1250
12	11.31	11.31	44.5	45.13	44.5	15.7	17	27.2	15.7	17	27.2	4626	4295
300	287	287	1130	1146	1130	400	432	692	400	432	692	2100	1950
14	12.44	12.44	49.5	50.25	49.5	19.3	18.9	30.7	18.7	18.5	30.1	6454	6057
350	315	315	1259	1276	1257	490	480	780	475	469	765	2930	2750
16	14.19	14.19	54.5	55.38	54.5	24.8	23.5	38.6	24.8	23.5	38.6	8194	7709
400	360	360	1384	1407	1384	629	598	980	629	598	980	3720	3500
18	16	16	60.5	61.38	(1)	24	24.4	39.4	24	24.4	39.4	12775	11013
450	406	406	1537	1559	(1)	610	620	1000	610	620	1000	5800	5100
20	17.88	17.88	65.5	66.38	(1)	25.6	25.6	41.9	25.6	25.6	41.9	19383	17621
500	454	454	1664	1686	(1)	650	650	1065	650	650	1065	8800	8000
24	21.5	21.5	76.5	77.63	(1)	29.9	31.4	50.2	29.9	31.4	50.2	28634	26432
600	546	546	1943	1972	(1)	760	798	1275	760	798	1275	13000	12000

ASME CLASS 1500 (PN 250) REDUCED BORE

Size in/mm	D	D1	L			Casting			Forging			Weight	
			RF	RTJ	BW	A	B	C	A	B	C	RF/RTJ (lb/kg)	BW (lb/kg)
2x1 1/2	1.93	1.5	14.5	14.62	14.5	4.3	4.5	8.5	4.3	4.5	8.5	95	75
50x40	49	38	368	371	368	108	115	215	108	115	215	43	34
2 1/2x2	2.44	1.93	16.5	16.63	16.5	4.3	5.5	9.6	4.3	5.5	9.6	150	139
65x50	62	49	419	422	419	108	140	245	108	140	245	68	63
3x2	2.94	1.93	18.5	18.63	18.5	4.3	5.5	10.6	4.3	5.5	10.6	189	167
80x50	74	49	470	473	470	108	140	265	108	140	265	86	76
4x3	3.94	2.94	21.5	21.63	21.5	6.1	7.4	12.2	6.1	7.4	12.2	414	388
100x80	100	74	546	549	546	155	187	310	155	187	310	188	176
6x4	5.69	3.94	27.75	28	27.75	7.8	7.9	15.6	7.8	7.9	15.6	678	645
150x100	144	100	705	711	705	198	201	395	198	201	395	308	293
8x6	7.56	5.69	32.75	33.13	32.75	9.6	11.3	19.1	9.6	11.3	19.1	1575	1476
200x150	192	144	832	841	832	243	288	485	243	288	485	715	670
10x8	9.44	7.56	39	39.38	39	11.6	12.8	23	11.6	12.8	23	2698	2533
250x200	239	192	991	1001	991	295	325	585	295	325	585	1225	1150
12x10	11.31	9.44	44.5	45.13	44.5	14.2	15.9	26.6	14.2	15.9	26.6	4031	3634
300x250	287	239	1130	1146	1130	360	405	675	360	405	675	1830	1650
14x10	12.44	9.44	49.5	50.25	49.5	14.2	15.9	29.5	14.2	15.9	29.5	5595	4846
350x250	315	239	1257	1276	1257	360	405	750	360	405	750	2540	2200
16x12	14.19	11.31	54.5	55.38	54.5	15.7	17	32.5	15.7	17	32.5	7390	6608
400x300	360	287	1384	1407	1384	400	432	825	400	432	825	3355	3000
18x14	16	12.44	60.5	61.38	60.5	18.7	18.5	36	18.7	18.5	36	10474	8811
450x350	406	315	1537	1559	1537	475	469	915	475	469	915	4755	4000
20x16	17.88	14.19	65.5	66.38	(1)	24.8	23.5	38.8	24.8	23.5	38.8	16079	14978
500x400	454	360	1664	1686	(1)	629	598	985	629	598	985	7300	6800
24x20	21.5	17.88	76.5	77.63	76.5	25.6	25.6	46.1	25.6	25.6	46.1	20220	17621
600x500	546	454	1943	1971	1943	650	650	1170	650	650	1170	9180	8000

(1) Contact our sales representative for more information.

TRUNNION BALL VALVE

DIMENSIONS AND WEIGHTS

ASME CLASS 2500 (PN 420)

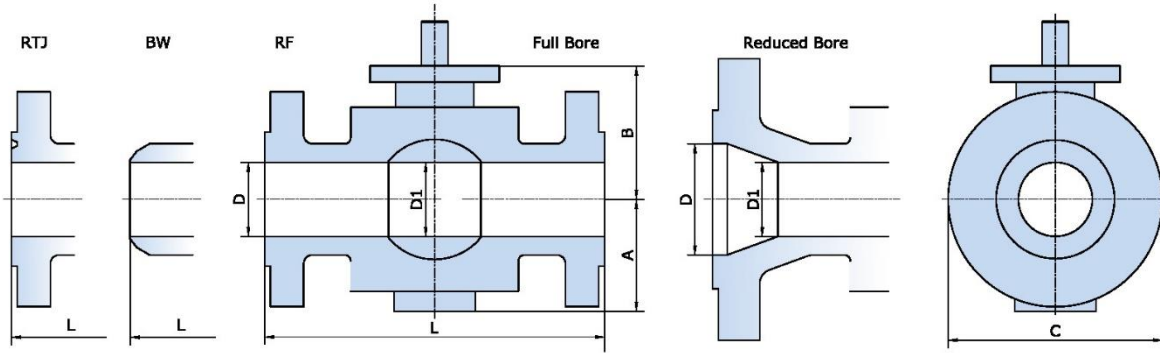

ASME CLASS 2500 (PN 420) FULL BORE

Size in/mm	D	D1	L			Casting			Forging			Weight	
			RF	RTJ	BW	A	B	C	A	B	C	RF/RTJ (lb/kg)	BW (lb/kg)
2	1.69	1.69	17.75	17.88	17.75	/	/	/	5.5	7.2	9.3	348	308
50	42	42	451	454	451	/	/	/	139	183	235	158	140
2 1/2	2.06	2.06	20.32	20.56	20.32	/	/	/	5.2	6.8	10.4	378	341
65	52	52	508	514	508	/	/	/	133	173	265	172	155
3	2.44	2.44	22.75	23	22.75	/	/	/	6.3	8.1	12	529	474
80	62	62	578	584	578	/	/	/	160	205	305	240	215
4	3.44	3.44	26.5	26.88	26.5	/	/	/	7.4	6.8	14	969	881
100	87	87	673	683	673	/	/	/	188	173	355	440	400
5	3.62	3.62	31.26	31.77	31.26	/	/	/	7.1	10	16.5	1652	1586
125	92	92	794	807	794	/	/	/	180	255	420	750	720
6	5.19	5.19	36	36.5	36	/	/	/	10.8	13.4	19.1	2115	1982
150	131	131	914	927	914	/	/	/	275	341	485	960	900
8	7.06	7.06	40.25	40.88	40.25	/	/	/	15	16.5	24.2	2885	2643
200	179	179	1022	1038	1022	/	/	/	380	418	615	1310	1200
10	8.81	8.81	50	50.88	50	/	/	/	18.9	20.5	31.9	4626	4295
250	223	223	1270	1292	1270	/	/	/	480	520	810	2110	1950
12	10.44	10.44	56	56.88	56	/	/	/	19.7	21.3	33.9	7115	6608
300	265	265	1422	1444	1422	/	/	/	500	540	860	3230	3000

ASME CLASS 2500 (PN 420) REDUCED BORE

Size in/mm	D	D1	L			Casting			Forging			Weight	
			RF	RTJ	BW	A	B	C	A	B	C	RF/RTJ (lb/kg)	BW (lb/kg)
2x1 1/2	1.69	1.5	17.75	17.88	17.75	/	/	/	4.6	5.5	9.3	275	231
50x40	42	38	368	454	451	/	/	/	118	140	235	125	105
2 1/2x2	2.06	1.69	20	20.25	20	/	/	/	5.5	7.2	10.4	330	297
65x50	52	42	508	514	508	/	/	/	139	183	265	150	135
3x2	2.44	1.69	22.75	23	22.75	/	/	/	5.5	7.2	12	430	396
80x50	62	42	578	584	578	/	/	/	139	183	305	195	180
4x3	3.44	2.66	26.5	26.88	26.5	/	/	/	7	10.4	14	859	771
100x80	87	62	673	683	673	/	/	/	178	265	355	390	350
6x4	5.19	3.44	36	36.5	36	/	/	/	9.6	10.7	19.1	1432	1322
150x100	131	87	914	927	914	/	/	/	243	273	485	650	600
8x6	7.06	5.19	40.25	40.88	40.25	/	/	/	10.8	13.4	21.7	2500	2203
200x150	179	131	1022	1038	1022	/	/	/	275	341	550	1135	1000
10x8	8.81	7.06	50	50.88	50	/	/	/	15	16.5	26.6	3778	3304
250x200	223	179	1270	1292	1270	/	/	/	380	418	675	1715	1500
12x10	10.44	8.81	56	56.88	56	/	/	/	18.9	20.5	31.9	5881	5286
300x250	265	223	1422	1445	1422	/	/	/	480	520	810	2670	2400

(1) Contact our sales representative for more information.

TRUNNION BALL VALVE

TOP MOUNTING DIMENSIONS AND TORQUE

NPS 2-4 (DN 50-100)

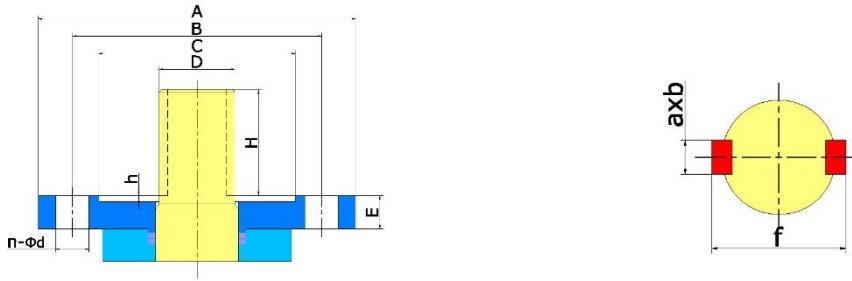

Size in/mm	Rating Class/PN	Torque ⁽¹⁾ ft-lb/N-m	ISO F#	A	B	C	D	h	E	n-Φd ⁽²⁾	H	Drive Key axb	f	Gearbox Model
2 50	150	44	F10	4.92	4.02	2.76	0.945	0.118	0.63	4-Φ0.472	1.575	0.315 x 0.276	1.063	GE-A1
	20	60	F10	125	102	70	24	3	16	4-Φ12	40	8x7	27	GE-A1
	300	81	F10	4.92	4.02	2.76	0.945	0.118	0.63	4-Φ0.472	1.575	0.315 x 0.276	1.063	GE-A1
	50	110	F10	125	102	70	24	3	16	4-Φ12	40	8x7	27	GE-A1
	600	111	F10	4.92	4.02	2.76	0.945	0.118	0.63	4-Φ0.472	1.575	0.315 x 0.276	1.063	GE-A1
	100	150	F10	125	102	70	24	3	16	4-Φ12	40	8x7	27	GE-A1
	900	133	F12	5.91	4.92	3.35	1.102	0.118	0.83	4-Φ0.551	1.772	0.315 x 0.276	1.063	GE-A2
	150	180	F12	150	125	85	28	3	21	4-Φ14	45	8x7	27	GE-A2
2 ½ 65	150	59	F10	4.92	4.02	2.76	0.945	30.118	0.63	4-Φ0.472	1.575	0.315 x 0.276	1.063	GE-A1
	20	80	F10	125	102	70	24	3	16	4-Φ12	40	8x7	27	GE-A1
	300	96	F10	4.92	4.02	2.76	0.945	30.118	0.63	4-Φ0.472	1.575	0.315 x 0.276	1.063	GE-A1
	50	130	F10	125	102	70	24	3	16	4-Φ12	40	8x7	27	GE-A1
	600	133	F12	5.91	4.92	3.35	1.102	0.118	0.83	4-Φ0.551	1.772	0.315 x 0.276	1.063	GE-A2
	100	180	F12	150	125	85	28	3	21	4-Φ14	45	8x7	27	GE-A2
	900	177	F12	5.91	4.92	3.35	1.102	0.118	0.83	4-Φ0.551	1.772	0.315 x 0.276	1.063	GE-A2
	150	240	F12	150	125	85	28	3	21	4-Φ14	45	8x7	27	GE-A2
3 80	150	221	F14	6.89	5.51	3.94	1.417	0.157	0.98	4-Φ0.709	2.362	0.394 x 0.315	1.339	GE-A3
	250	300	F14	175	140	100	36	4	25	4-Φ18	60	10x8	34	GE-A3
	2500	354	F16	8.27	6.5	5.12	1.575	0.197	1.18	4-Φ0.866	2.362	0.472 x 0.315	1.693	GE-A4
	420	480	F16	210	165	130	40	5	30	4-Φ22	60	12x8	43	GE-A4
	150	74	F10	4.92	4.02	2.76	0.945	0.118	0.87	4-Φ0.472	1.575	0.315 x 0.276	1.063	GE-A1
	20	100	F10	125	102	70	24	3	22	4-Φ12	40	8x7	27	GE-A1
	300	96	F10	4.92	4.02	2.76	0.945	0.118	0.87	4-Φ0.472	1.575	0.315 x 0.276	1.063	GE-A1
	50	130	F10	125	102	70	24	3	22	4-Φ12	40	8x7	27	GE-A1
4 100	600	148	F12	5.91	4.92	3.35	1.102	0.118	0.91	4-Φ0.551	1.772	0.315 x 0.276	1.063	GE-A2
	100	200	F12	150	125	85	28	3	23	4-Φ14	45	8x7	27	GE-A2
	900	207	F14	6.89	5.51	3.94	1.417	0.157	0.98	4-Φ0.709	2.362	0.394 x 0.315	1.339	GE-A3
	150	280	F14	175	140	100	36	4	25	4-Φ18	60	10x8	34	GE-A3
	1500	354	F14	6.89	5.51	3.94	1.417	0.157	0.98	4-Φ0.709	2.362	0.394 x 0.315	1.339	GE-A3
	250	480	F14	175	140	100	36	4	25	4-Φ18	60	10x8	34	GE-A3
	2500	443	F16	8.27	6.5	5.12	1.772	0.197	1.18	4-Φ0.866	2.756	0.551 x 0.354	1.949	GE-A4
	420	600	F16	210	165	130	45	5	30	4-Φ22	70	14x9	49.5	GE-A4
4 100	150	89	F12	5.91	4.92	3.35	1.102	0.118	0.91	4-Φ0.551	1.772	0.315 x 0.276	1.063	GE-A2
	20	120	F12	150	125	85	28	3	23	4-Φ14	45	8x7	27	GE-A2
	300	133	F12	5.91	4.92	3.35	1.102	0.118	0.91	4-Φ0.551	1.772	0.315 x 0.276	1.063	GE-A2
	50	180	F12	150	125	85	28	3	23	4-Φ14	45	8x7	27	GE-A2
	600	207	F14	6.89	5.51	3.94	1.417	0.157	0.98	4-Φ0.709	2.362	0.394 x 0.315	1.339	GE-A3
	100	280	F14	175	140	100	36	4	25	4-Φ18	60	10x8	34	GE-A3
	900	369	F14	6.89	5.51	3.94	1.417	0.157	0.98	4-Φ0.709	2.362	0.394 x 0.315	1.339	GE-A3
	150	500	F14	175	140	100	36	4	25	4-Φ18	60	10x8	34	GE-A3
4 100	1500	590	F16	8.27	6.5	5.12	1.772	0.197	1.18	4-Φ0.866	2.756	0.551 x 0.354	1.949	GE-A4
	250	800	F16	210	165	130	45	5	30	4-Φ22	70	14x9	49.5	GE-A4
	2500	1475	F16	8.27	6.5	5.12	1.969	0.197	1.18	4-Φ0.866	2.756	0.551 x 0.354	2.244	GE-A5
	420	2000	F16	210	165	130	50	5	30	4-Φ22	70	14x9	57	GE-A5

Note:

(1) Torque doesn't include safety factor. The torque is based on seats of PTFE/RPTFE (Class 150 – 300), Nylon (Class 900 – 1500), and PEEK (Class 2500). Torque shall be as listed if other than the base seat material is selected:

PTFE/RPTFE	Nylon	Devlon	PCTFE	TFM	Delrin	Molon	PPL	PEEK	Metal
Base	x 1	x 1	x 0.8	X 0.8	x 1	X 1	X 0.8	x 1.3	x 2.2

(2) Number of bolt holes and bolt hole diameter.

TRUNNION BALL VALVE

TOP MOUNTING DIMENSIONS AND TORQUE (CONT'D)

NPS 6-10 (DN 150-300)

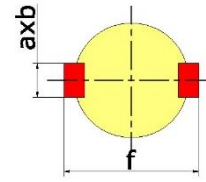
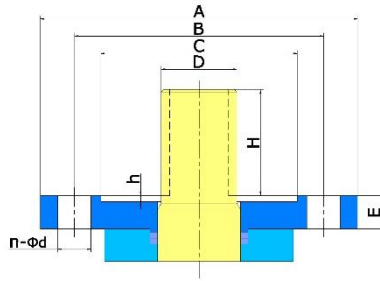

Size in/mm	Rating Class/PN	Torque ⁽¹⁾ ft-Lb/N-m	ISO F#	A	B	C	D	h	E	n-Φd ⁽²⁾	H	Drive Key a x b	f	Gearbox Model
6 150	150	369	F16	8.27	6.5	5.12	1.417	0.197	0.984	4-Φ0.866	2.756	0.551 x 0.315	1.339	GE-A3
	20	500	F16	210	165	130	36	5	25	4-Φ22	70	10 x 8	34	GE-A3
	300	516	F16	8.27	6.5	5.12	1.417	0.197	0.984	4-Φ0.866	2.756	0.551 x 0.315	1.339	GE-A3
	50	700	F16	210	165	130	36	5	25	4-Φ22	70	10 x 8	34	GE-A3
	600	811	F16	8.27	6.5	5.12	1.772	0.197	1.181	4-Φ0.866	2.756	0.551 x 0.354	1.949	GE-A4
	100	1100	F16	210	165	130	45	5	30	4-Φ22	70	14 x 9	49.5	GE-A4
	900	1549	F16	8.27	6.5	5.12	1.969	0.197	1.181	4-Φ0.866	2.756	0.551 x 0.354	2.244	GE-A5
	150	2100	F16	210	165	130	50	5	30	4-Φ22	70	14 x 9	57	GE-A5
8 200	1500	2213	F16	8.27	6.5	5.12	2.165	0.197	1.181	4-Φ0.866	3.15	0.63 x 0.394	2.48	GE-A6
	250	3000	F16	210	165	130	55	5	30	4-Φ22	80	16 x 10	63	GE-A6
	2500	3688	F25	11.81	10	7.87	2.559	0.197	1.378	4-Φ0.709	3.543	0.709 x 0.433	2.874	GE-A9
	420	5000	F25	300	254	200	65	5	35	4-Φ18	90	18 x 11	73	GE-A9
	150	443	F16	8.27	6.5	5.12	1.772	0.197	1.181	4-Φ0.866	2.756	0.551 x 0.354	1.949	GE-A4
	20	600	F16	210	165	130	45	5	30	4-Φ22	70	14 x 9	49.5	GE-A4
	300	811	F16	8.27	6.5	5.12	1.772	0.197	1.181	4-Φ0.866	2.756	0.551 x 0.354	1.949	GE-A4
	50	1100	F16	210	165	130	45	5	30	4-Φ22	70	14 x 9	49.5	GE-A4
10 250	600	1401	F16	8.27	6.5	5.12	1.969	0.197	1.181	4-Φ0.866	2.756	0.551 x 0.354	2.244	GE-A6
	100	1900	F16	210	165	130	50	5	30	4-Φ22	70	14 x 9	57	GE-A6
	900	2581	F25	11.81	10	7.87	2.165	0.197	1.181	8-Φ0.709	3.15	0.63 x 0.394	2.48	GE-A8
	150	3500	F25	300	254	200	55	5	30	8-Φ18	80	16 x 10	63	GE-A8
	1500	4794	F25	11.81	10	7.87	2.756	0.197	1.496	8-Φ0.709	3.937	0.787 x 0.472	3.11	GE-B1
	250	6500	F25	300	254	200	70	5	38	8-Φ18	100	20 x 12	79	GE-B1
	2500	6269	F30	13.78	11.73	9.06	3.543	0.197	1.496	8-Φ0.866	4.724	0.984 x 0.551	3.937	GE-B2
	420	8500	F30	350	298	230	90	5	38	8-Φ22	120	25 x 14	100	GE-B2
12 300	150	738	F16	8.27	6.5	5.12	1.969	0.197	1.063	4-Φ0.866	2.756	0.551 x 0.354	2.244	GE-A5
	20	1000	F16	210	165	130	50	5	27	4-Φ22	70	14 x 9	57	GE-A5
	300	1475	F16	8.27	6.5	5.12	1.969	0.197	1.063	4-Φ0.866	2.756	0.551 x 0.354	2.244	GE-A5
	50	2000	F16	210	165	130	50	5	27	4-Φ22	70	14 x 9	57	GE-A5
	600	2581	F25	11.81	10	7.87	2.559	0.197	1.260	8-Φ0.709	3.543	0.709 x 0.433	2.874	GE-A8
	100	3500	F25	300	254	200	65	5	32	8-Φ18	90	18 x 11	73	GE-A8
	900	4057	F25	11.81	10	7.87	2.756	0.197	1.417	8-Φ0.709	3.937	0.787 x 0.472	3.11	GE-A9
	150	5500	F25	300	254	200	70	5	36	8-Φ18	100	20 x 12	79	GE-A9
12 300	1500	7744	F30	13.78	11.73	9.06	3.543	0.197	1.496	8-Φ0.866	4.724	0.984 x 0.551	3.937	GE-B3
	250	10500	F30	350	298	230	90	5	38	8-Φ22	120	25 x 14	100	GE-B3
	2500	16226	F35	16.34	14.02	10.24	3.937	0.197	1.575	8-Φ1.299	5.512	1.102 x 0.63	4.409	GE-B5
	420	22000	F35	415	356	260	100	5	40	8-Φ33	140	28 x 16	112	GE-B5
	150	1106	F25	11.81	10	7.87	2.362	0.197	1.378	8-Φ0.709	3.15	0.709 x 0.433	2.677	GE-A7
	20	1500	F25	300	254	200	60	5	35	8-Φ18	80	18 x 11	68	GE-A7
	300	2065	F25	11.81	10	7.87	2.362	0.197	1.378	8-Φ0.709	3.15	0.709 x 0.433	2.677	GE-A8
	50	2800	F25	300	254	200	60	5	35	8-Φ18	80	18 x 11	68	GE-A8
12 300	600	4057	F25	11.81	10	7.87	2.756	0.197	1.378	8-Φ0.709	3.937	0.787 x 0.472	3.11	GE-A9
	100	5500	F25	300	254	200	70	5	35	8-Φ18	100	20 x 12	79	GE-A9
	900	6491	F30	13.78	11.73	9.06	3.543	0.197	1.496	8-Φ0.866	4.724	0.984 x 0.551	3.937	GE-B2
	150	8800	F30	350	298	230	90	5	38	8-Φ22	120	25 x 14	100	GE-B2
	1500	11801	F35	16.34	10.24	14.02	3.937	0.197	1.575	8-Φ1.299	5.512	1.102 x 0.63	4.409	GE-B4
	250	16000	F35	415	260	356	100	5	40	8-Φ33	140	28 x 16	112	GE-B4
	2500	18070	F35	16.34	10.24	14.02	3.937	0.197	1.575	8-Φ1.299	5.512	1.102 x 0.63	4.409	GE-C3
	420	24500	F35	415	260	356	100	5	40	8-Φ33	140	28 x 16	112	GE-C3

Note:

(1) Torque doesn't include safety factor. The torque is based on seats of PTFE/RPTFE (Class 150 – 300), Nylon (Class 900 – 1500), and PEEK (Class 2500). Torque shall be as follows if other than the base seat material is selected:

PTFE/RPTFE	Nylon	Devlon	PCTFE	TFM	Delrin	Molon	PPL	PEEK	Metal
Base	x 1	x 1	x 0.8	X 0.8	x 1	X 1	X 0.8	x 1.3	x 2.2

(2) Number of bolt holes and bolt hole diameter.

TRUNNION BALL VALVE

TOP MOUNTING DIMENSIONS AND TORQUE (CONT'D)

NPS 14-24 (DN 350-600)

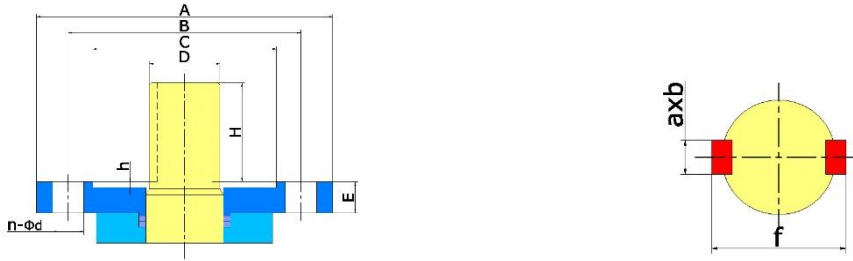

Size in/mm	Rating Class/PN	Torque ⁽¹⁾ ft-lb/N-m	ISO F#	A	B	C	D	h	E	n-Φd ⁽²⁾	H	Drive Key a x b	f	Gearbox Model	
14 350	150	1328	F25	11.81	10	7.87	2.559	0.197	1.299	8-Φ0.709	3.543	0.709 x 0.433	2.874	GE-A7	
	20	1800		300	254	200	65	5	33	8-Φ18	90	18x11	73		
	300	2655	F25	11.81	10	7.87	2.559	0.197	1.299	8-Φ0.709	3.543	0.709 x 0.433	2.874	GE-A9	
		50		3600	300	254	200	65	5	33	8-Φ18	90	18x11		73
	600	5163	F25	11.81	10	7.87	3.15	0.197	1.378	8-Φ0.709	4.724	0.866 x 0.551	3.543	GE-B1	
		100		7000	300	254	200	80	5	35	8-Φ18	120	22x14		90
		900	8998	F30	13.78	11.73	9.06	3.937	0.197	1.378	8-Φ0.866	5.512	1.102 x 0.63	4.409	GE-B3
		150	12200		350	298	230	100	5	35	8-Φ22	140	28x16	112	
1500	13276	F35	16.34	14.02	10.24	3.937	0.197	1.575	8-Φ1.299	5.512	1.102 x 0.63	4.409	GE-B5		
	250		18000	415	356	260	100	5	40	8-Φ33	140	28x16		112	
16 400	150	2508	F25	11.81	10	7.78	3.15	0.197	1.378	8-Φ0.709	4.724	0.866 x 0.551	3.543	GE-A8	
	20	3400		300	254	200	80	5	35	8-Φ18	120	22x14	90		
	300	4720	F25	11.81	10	7.78	3.15	0.197	1.378	8-Φ0.709	4.724	0.866 x 0.551	3.543	GE-A9	
		50		6400	300	254	200	80	5	35	8-Φ18	120	22x14		90
	600	8113	F30	13.78	11.73	9.06	3.937	0.197	1.378	8-Φ0.866	5.512	1.102 x 0.63	4.409	GE-B3	
		100		11000	350	298	230	100	5	35	8-Φ22	140	28x16		112
	900	11432	F35	16.34	14.02	10.24	3.937	0.197	1.575	8-Φ1.299	5.512	1.102 x 0.63	4.409	GE-B4	
		150		15500	415	356	260	100	5	40	8-Φ33	140	28x16		112
1500	18439	F40	18.7	15.98	11.81	34.724	0.315	1.772	8-Φ1.535	6.299	1.26 x 0.709	5.276	GE-C5		
	250		25000	475	406	300	120	8	45	8-Φ39	160	32x18		134	
18 450	150	2950	F25	11.81	10	7.87	3.15	0.197	1.378	8-Φ0.709	4.724	0.866 x 0.551	3.543	GE-A9	
	20	4000		300	254	200	80	5	35	8-Φ18	120	22x14	90		
	300	5532	F25	11.81	10	7.87	3.15	0.197	1.378	8-Φ0.709	4.724	0.866 x 0.551	3.543	GE-A9	
		50		7500	300	254	200	80	5	35	8-Φ18	120	22x14		90
	600	11063	F35	16.34	14.02	10.24	3.937	0.197	1.575	8-Φ1.299	5.512	1.102 x 0.63	4.409	GE-B4	
		100		15000	415	356	260	100	5	40	8-Φ33	140	28x16		112
	900	16226	F35	16.34	14.02	10.24	4.724	0.197	1.575	8-Φ1.299	6.299	1.26 x 0.709	5.276	GE-B5	
		150		22000	415	356	260	120	5	40	8-Φ33	160	32x18		134
1500	26552	F40	18.7	15.98	11.81	5.512	0.315	1.772	8-Φ1.535	6.693	1.417 x 0.787	6.142	GE-B6		
	250		36000	475	406	300	140	8	45	8-Φ39	170	36x20		156	
20 500	150	3319	F30	13.78	11.73	9.06	3.543	0.197	1.496	8-Φ0.866	4.724	0.984 x 0.551	3.937	GE-B2	
	20	4500		350	298	230	90	5	38	8-Φ22	120	25x14	100		
	300	7007	F30	13.78	11.73	9.06	3.543	0.197	1.496	8-Φ0.866	4.724	0.984 x 0.551	3.937	GE-B3	
		50		9500	350	298	230	90	5	38	8-Φ22	120	25x14		100
	600	14014	F35	16.34	14.02	10.24	3.937	0.197	1.575	8-Φ1.299	5.512	1.102 x 0.63	4.409	GE-B5	
		100		19000	415	356	260	100	5	40	8-Φ33	140	28x16		112
	900	22864	F40	18.7	15.98	11.81	4.724	0.315	1.772	8-Φ1.535	6.299	1.26 x 0.709	5.276	GE-B6	
		150		31000	475	406	300	120	8	45	8-Φ39	160	32x18		134
1500	35624	F48	22.05	19.02	14.57	5.512	0.315	1.772	12-Φ1.535	6.693	1.417 x 0.787	6.142	GE-B7		
	250		48300	560	483	370	140	8	45	12-Φ39	170	36x20		156	
24 600	150	5900	F35	16.34	14.02	10.24	3.937	0.197	1.575	8-Φ1.299	5.512	1.102 x 0.63	4.409	GE-B4	
	20	8000		415	356	260	100	5	40	8-Φ33	140	28x16	112		
	300	12907	F35	16.34	14.02	10.24	3.937	0.197	1.575	8-Φ1.299	5.512	1.102 x 0.63	4.409	GE-B4	
		50		17500	415	356	260	100	5	40	8-Φ33	140	28x16		112
	600	23602	F40	18.7	15.98	11.81	4.724	0.315	1.772	8-Φ1.535	6.299	1.26 x 0.709	5.276	GE-B6	
		100		32000	475	406	300	120	8	45	8-Φ39	160	32x18		134
	900	36878	F48	22.05	19.02	14.57	5.512	0.315	1.772	12-Φ1.535	6.693	1.417 x 0.787	6.142	GE-B7	
		150		50000	560	483	370	140	8	45	12-Φ39	170	36x20		156
1500	66380	F60	27.01	23.74	18.5	6.299	0.315	2.362	20-Φ1.535	7.48	1.575 x 0.866	7.008	GE-C7		
	250		90000	686	603	470	160	8	60	20-Φ39	190	40x22		178	

Note:

(1) Torque doesn't include safety factor. The torque is based on seats of PTFE/RPTFE (Class 150 – 300), Nylon (Class 900 – 1500), and PEEK (Class 2500). Torque shall be as follows if other than the base seat material is selected:

PTFE/RPTFE	Nylon	Devlon	PCTFE	TFM	Delrin	Molon	PPL	PEEK	Metal
Base	x 1	x 1	x 0.8	X 0.8	x 1	X 1	X 0.8	x 1.3	x 2.2

(2) Number of bolt holes and bolt hole diameter.



TRUNNION BALL VALVE

TOP MOUNTING DIMENSIONS AND TORQUE (CONT'D)

NPS 26-40 (DN 650-1000)

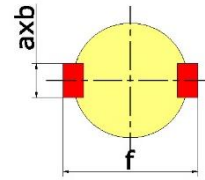
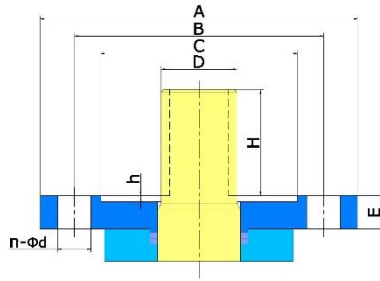

Size in/mm	Rating Class/PN	Torque ⁽¹⁾ ft-lb/N-m	ISO F#	A	B	C	D	h	E	n-Φd ⁽²⁾	H	Drive Key a x b	f	Gearbox Model
26 650	150	6269	F35	16.34	14.02	10.24	3.937	0.197	1.575	8-Φ1.299	5.512	1.102 x 0.63	4.409	GE-B4
	20	8500		415	356	260	100	5	40	8-Φ33	140	28x16	112	
	300	13276	F35	16.34	14.02	10.24	3.937	0.197	1.575	8-Φ1.299	5.512	1.102 x 0.63	4.409	GE-B5
	50	18000		415	356	260	100	5	40	8-Φ33	140	28x16	112	
	600	25077	F40	18.7	15.98	11.81	4.724	0.315	1.772	8-Φ1.535	6.299	1.26 x 0.709	5.276	GE-B6
	100	34000		475	406	300	120	8	45	8-Φ39	160	32x18	134	
900	42041	F48	22.05	19.02	14.57	5.512	0.315	1.772	12-Φ1.535	6.693	1.417 x 0.787	6.142	GE-B7	
150	57000		560	483	370	140	8	45	12-Φ39	170	36x20	156		
28 700	150	6638	F35	16.34	14.02	10.24	3.937	0.197	1.575	8-Φ1.299	5.512	1.102 x 0.63	4.409	GE-B4
	20	9000		415	356	260	100	5	40	8-Φ33	140	28x16	112	
	300	16226	F35	16.34	14.02	10.24	3.937	0.197	1.575	8-Φ1.299	5.512	1.102 x 0.63	4.409	GE-B5
	50	22000		415	356	260	100	5	40	8-Φ33	140	28x16	112	
	600	30978	F48	22.05	19.02	14.57	5.512	0.315	1.772	12-Φ1.535	6.693	1.417 x 0.787	6.142	GE-B7
	100	42000		560	483	370	140	8	45	12-Φ39	170	36x20	156	
900	46465	F48	22.05	19.02	14.57	5.512	0.315	1.772	12-Φ1.535	6.693	1.417 x 0.787	6.142	GE-B7	
150	63000		560	483	370	140	8	45	12-Φ39	170	36x20	156		
30 750	150	8851	F35	16.34	14.02	10.24	3.937	0.197	1.575	8-Φ1.299	5.512	1.102 x 0.63	4.409	GE-B4
	20	12000		415	356	260	100	5	40	8-Φ33	140	28x16	112	
	300	19914	F40	18.7	15.98	11.81	4.724	0.315	1.772	8-Φ1.535	6.299	1.26 x 0.709	5.276	GE-B6
	50	27000		475	406	300	120	8	45	8-Φ39	160	32x18	134	
	600	37616	F48	22.05	19.02	14.57	5.512	0.315	1.772	12-Φ1.535	6.693	1.417 x 0.787	6.142	GE-C5
	100	51000		560	483	370	140	8	45	12-Φ39	170	36x20	156	
900	55317	F48	22.05	19.02	14.57	6.299	0.315	1.969	12-Φ1.535	7.48	1.575 x 0.866	7.008	GE-B7	
150	75000		560	483	370	160	8	50	12-Φ39	190	40x22	178		
32 800	150	9957	F35	16.34	14.02	10.24	4.724	0.197	1.575	8-Φ1.299	6.299	1.26 x 0.709	5.276	GE-B5
	20	13500		415	356	260	120	5	40	8-Φ33	160	32x18	134	
	300	22864	F40	18.7	15.98	11.81	4.724	0.315	1.772	8-Φ1.535	6.299	1.26 x 0.709	5.276	GE-B6
	50	31000		475	406	300	120	8	45	8-Φ39	160	32x18	134	
	600	44254	F48	22.05	19.02	14.57	5.512	0.315	1.772	12-Φ1.535	6.693	1.417 x 0.787	6.142	GE-C5
	100	60000		560	483	370	140	8	45	12-Φ39	170	36x20	156	
900	55317	F48	22.05	19.02	14.57	6.299	0.315	1.969	12-Φ1.535	7.48	1.575 x 0.866	7.008	GE-B7	
150	75000		560	483	370	160	8	50	12-Φ39	190	40x22	178		
34 850	150	11432	F35	16.34	14.02	10.24	4.724	0.197	1.575	8-Φ1.299	6.299	1.26 x 0.709	5.276	GE-B5
	20	15500		415	356	260	120	5	40	8-Φ33	160	32x18	134	
	300	26921	F40	18.7	15.98	11.81	5.512	0.315	1.772	8-Φ1.535	6.693	1.417 x 0.787	6.142	GE-B6
	50	36500		475	406	300	140	8	45	8-Φ39	170	36x20	156	
	600	51629	F48	22.05	19.02	14.57	6.299	0.315	1.969	12-Φ1.535	7.48	1.575 x 0.866	7.008	GE-B7
	100	70000		560	483	370	160	8	50	12-Φ39	190	40x22	178	
900	55317	F48	22.05	19.02	14.57	6.299	0.315	1.969	12-Φ1.535	7.48	1.575 x 0.866	7.008	GE-B7	
150	75000		560	483	370	160	8	50	12-Φ39	190	40x22	178		
36 900	150	12539	F35	16.34	14.02	10.24	4.724	0.197	1.575	8-Φ1.299	6.299	1.26 x 0.709	5.276	GE-B5
	20	17000		415	356	260	120	5	40	8-Φ33	160	32x18	134	
	300	28765	F40	18.7	15.98	11.81	5.512	0.315	1.772	8-Φ1.535	6.693	1.417 x 0.787	6.142	GE-B6
	50	39000		475	406	300	140	8	45	8-Φ39	170	36x20	156	
	600	56055	F48	22.05	19.02	14.57	6.299	0.315	1.969	12-Φ1.535	7.48	1.575 x 0.866	7.008	GE-B7
	100	76000		560	483	370	160	8	50	12-Φ39	190	40x22	178	
900	55317	F48	22.05	19.02	14.57	6.299	0.315	1.969	12-Φ1.535	7.48	1.575 x 0.866	7.008	GE-B7	
150	75000		560	483	370	160	8	50	12-Φ39	190	40x22	178		
40 1000	150	18439	F40	18.7	15.98	11.81	7.724	0.315	1.772	8-Φ1.535	6.299	1.26 x 0.709	5.276	GE-B6
	20	25000		475	406	300	120	8	45	8-Φ39	160	32x18	134	
	300	36878	F48	22.05	19.02	14.57	5.512	0.315	1.969	12-Φ1.535	6.693	1.417 x 0.787	6.142	GE-C5
	50	50000		560	483	370	140	8	50	12-Φ39	170	36x20	156	
	600	66380	F60	27.01	23.74	18.5	6.299	0.315	2.362	20-Φ1.535	7.48	1.575 x 0.866	7.008	GE-C7
	100	90000		686	603	470	160	8	60	20-Φ39	190	40x22	178	

Note:

(1) Torque doesn't include safety factor. The torque is based on seats of PTFE/RPTFE (Class 150 – 300), Nylon (Class 900 – 1500), and PEEK (Class 2500). Torque shall be as follows if other than the base seat material is selected:

PTFE/RPTFE	Nylon	Devlon	PCTFE	TFM	Delrin	Molon	PPL	PEEK	Metal
Base	x 1	x 1	x 0.8	X 0.8	x 1	X 1	X 0.8	x 1.3	x 2.2

(2) Number of bolt holes and bolt hole diameter.

TRUNNION BALL VALVE

TOP MOUNTING DIMENSIONS AND TORQUE (CONT'D)

NPS 42-56 (DN 1050-1400)

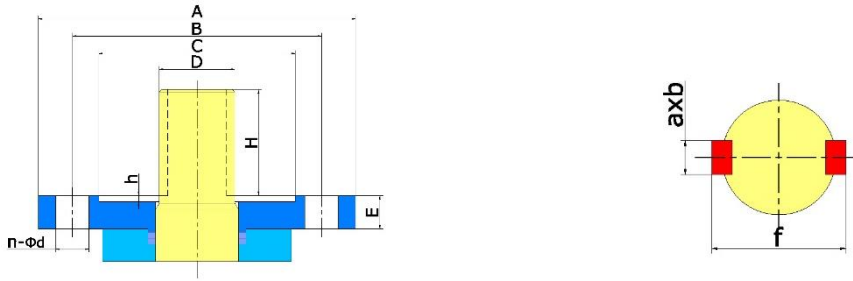

Size in/mm	Rating Class/PN	Torque ⁽¹⁾ ft-lb/N-m	ISO F#	A	B	C	D	h	E	n-Φd ⁽²⁾	H	Drive Key a x b	f	Gearbox Model
42 1050	150	20652	F40	18.7	15.98	11.81	4.724	0.315	1.772	8-Φ1.535	6.299	1.26 x 0.709	5.276	GE-B6
	20	28000		475	406	300	120	8	45	8-Φ39	160	32x18	134	
	300	40566	F48	22.05	19.02	14.57	5.512	0.315	1.969	12-Φ1.535	6.693	1.417 x 0.787	6.142	GE-B7
	50	55000		560	483	370	140	8	50	12-Φ39	170	36x20	156	
48 1200	600	81132	F60	27.01	23.74	18.5	6.299	0.315	2.362	20-Φ1.535	7.48	1.575 x 0.866	7.008	GE-C7
	100	110000		686	603	470	160	8	60	20-Φ39	190	40x22	178	
	150	33190	F40	18.7	15.98	11.81	5.512	0.315	1.772	8-Φ1.535	6.693	1.417 x 0.787	6.142	GE-C5
	20	45000		475	406	300	140	8	45	8-Φ39	170	36x20	156	
56 1400	300	66380	F60	27.01	23.74	18.5	6.299	0.315	2.362	20-Φ1.535	7.48	1.575 x 0.866	7.008	GE-C7
	50	90000		686	603	470	160	8	60	20-Φ39	190	40x22	178	
	600	125385	F60	27.01	23.74	18.5	7.874	0.315	2.362	20-Φ1.535	9.25	1.772 x 0.984	8.661	(3)
	100	170000		686	603	470	200	8	60	20-Φ39	235	45x25	220	
56 1400	150	40566	F48	22.05	19.02	14.57	6.299	0.315	1.969	12-Φ1.535	7.48	1.575 x 0.866	7.008	GE-B7
	20	55000		560	483	370	160	8	50	12-Φ39	190	40x22	178	
	300	92195	F60	27.01	23.74	18.5	7.087	0.315	2.165	20-Φ1.535	8.661	1.772 x 0.984	7.874	GE-C7
	50	125000		686	603	470	180	8	55	20-Φ39	220	45x25	200	
56 1400	600	177014	F60	27.01	23.74	18.5	7.874	0.315	2.362	20-Φ1.535	9.252	1.772 x 0.984	8.661	(3)
	100	240000		686	603	470	200	8	60	20-Φ39	235	45x25	220	

Note:

(1) Torque doesn't include safety factor. The torque is based on seats of PTFE/RPTFE (Class 150 – 300), Nylon (Class 900 – 1500), and PEEK (Class 2500). Torque shall be as follows if other than the base seat material is selected:

PTFE/RPTFE	Nylon	Devlon	PCTFE	TFM	Delrin	Molon	PPL	PEEK	Metal
Base	x 1	x 1	x 0.8	X 0.8	x 1	X 1	X 0.8	x 1.3	x 2.2

(2) Number of bolt holes and bolt hole diameter.

(3) Please consult our sales representative for gearbox selection.

TRUNNION BALL VALVE

GEAR OPERATORS

DIMENSIONS AND WEIGHTS

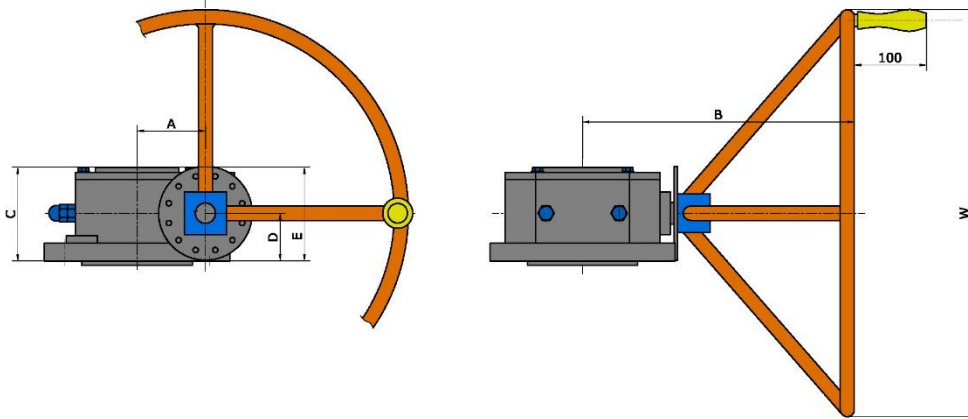

Gearbox Model	ISO F#	A	B	C	D	E	W	Gear Ratio	Weight lb/kg	Input Torque ft-lb/N-m	Output Torque ft-lb/N-m
GE-A1	F10	2.5 63	8.4 214	2.4 60	1.3 33	2.8 72	13.8 350	38:1	18 8	59 80	406 550
GE-A2	F12	3 75	8.8 223	3 75	1.6 40	3.4 87	13.8 350	54:1	24 11	66 90	701 950
GE-A3	F14	3.4 87	9.3 236	3.5 90	2.1 54	4.2 106	13.8 350	50:1	33 15	92 125	959 1300
GE-A4	F16	4.1 105	9.3 236	3.5 90	2.1 54	4.2 106	13.8 350	50:1	37 17	92 125	959 1300
GE-A5	F16	4.1 105	12.2 310	3.5 90	2.1 54	4.2 106	18.1 460	72:1	55 25	122 165	1623 2200
GE-A6	F16	4.1 105	14.8 375	3.7 95	2.1 54	4.4 112	23.6 600	68:1	88 40	144 195	2360 3200
GE-A7	F25	5.9 150	14.8 375	3.7 95	2.1 54	4.4 112	23.6 600	68:1	106 48	144 195	2360 3200
GE-A8	F25	5.9 150	16.9 430	5.3 135	7.1 180	6 153	23.6 600	85:1	179 81	144 195	3098 4200
GE-A9	F25	5.9 150	20.1 510	5.3 135	7.1 180	6 153	23.6 600	200:1	198 90	144 195	5310 7200
GE-B1	F25	6.1 155	20.9 532	5.5 140	3 77	6.5 166	23.6 600	275:1	229 104	144 195	7449 10100
GE-B2	F30	6.1 155	20.9 532	5.5 140	3 77	6.5 166	23.6 600	275:1	229 104	144 195	7449 10100
GE-B3	F30	6.8 172	21.9 557	5.7 145	2.9 74	6.6 168	23.6 600	433:1	278 126	144 195	10695 14500
GE-B4	F35	8.1 207	22.8 579	6.5 165	3.3 84	7.5 190	23.6 600	518:1	348 158	144 195	13719 18600
GE-B5	F35	8.3 212	25.2 641	6.5 165	3.4 87	7.2 183	23.6 600	664:1	459 208	144 195	18070 24500
GE-B6	F40	10.4 265	29.3 744	8.1 205	4.3 109	8.9 225	23.6 600	1281:1	725 329	144 195	31346 42500
GE-B7	F48	11 280	33.3 847	8.9 225	4.8 122	9.7 247	27.6 700	1840:1	1213 550	177 240	62471 84700
GE-C1	F30	7.2 183	26.8 680	5.3 135	2.7 68	6 152	15.7 400	372:1	311 141	144 195	11063 15000
GE-C2	F30	7.2 183	28.7 728	5.3 135	2.7 68	6 152	15.7 400	955:1	322 146	92 125	16226 22000
GE-C3	F35	8.5 216	28.4 721	5.9 150	2.3 82	7.3 185	19.7 500	402:1	573 260	162x2 220x2 ⁽¹⁾	327450 37000
GE-C4	F35	8.5 216	29.1 738	5.9 150	2.3 82	7.3 185	19.7 500	1032:1	423 192	162 220	30978 42000
GE-C5	F40	9.7 247	30.2 768	7.1 180	3.6 91	8 203	23.6 600	1232:1	529 240	162 220	38353 52000
GE-C6	F48	11.5 292	35.4 898	7.7 195	4.1 103	8.9 226	27.6 700	838:1	893 405	207x2 280x2 ⁽¹⁾	62693 85000
GE-C7	F60	14.2 360	40.1 1018	10.2 260	5.3 135	11.9 303	35.4 900	1560:1	2555 1159	207x2 280x2 ⁽¹⁾	118010 160000

Note:

(1) Requires 2 persons to operate.

TRUNNION BALL VALVE

SEAT AND SEAL MATERIAL

SELECTION GUIDE

Seat Material Pressure-Temperature Rating (Operating)

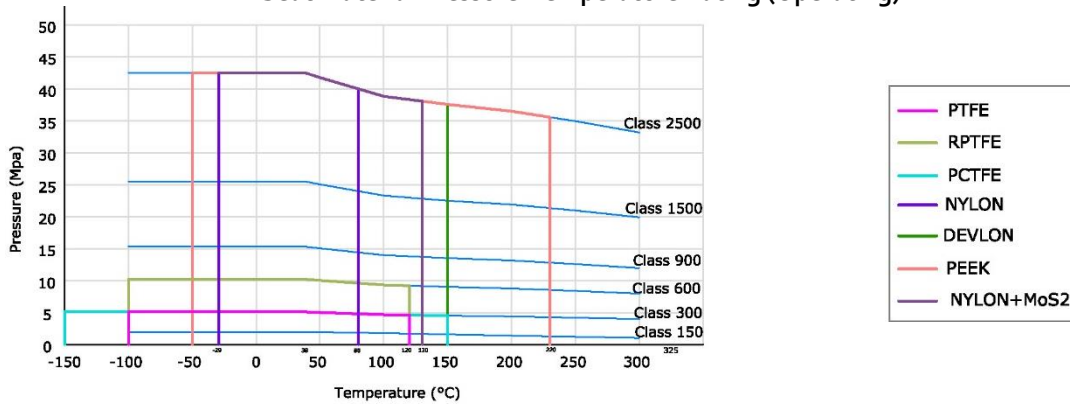

SEAT MATERIALS

Material Name	Description	Operating Temperature	Operating Pressure	Service Application
PTFE	Virgin PTFE is the most widely used sealing material with excellent characteristics suitable for most services. It has excellent chemical resistance throughout valve industries and low coefficient of friction.	-112°F – 248°F -80°C – 120°C	Class 150 PN 20	General chemicals, low pressure services.
RPTFE	RPTFE (Reinforced PTFE) is typically produced by adding 15% fiber glass to virgin PTFE. It has better pressure-temperature properties than virgin PTFE, better resistance to wear and deformation under load. NOT to be used in hydrofluoric acid	-112°F – 248°F -80°C – 120°C	Class 150 – 600 PN 20 – 100	For low and medium pressure services.
PCTFE	PCTFE is a homopolymer of chlorotrifluoroethylene, featuring high compressive strength and low deformation under load.	-320°F – 248°F -196°C – 120°C	Class 150 – 300 PN 20 – 50	For low temperature low pressure services.
Nylon 6	Nylon is a common seat material for Class 600 valves. It is highly resistance to many chemicals and abrasions, and can be used in air, oil and other gas media. It is NOT suitable for strong oxidization agents.	-22°F – 176°F -30°C – 80°C	Class 150 – 1500 PN 20 – 250	For high pressure, low temperature services.
Devlon®	Devlon® is a high molecular weight polyamide that is specifically tailored for high temperature/pressure applications in the offshore oil and gas sector. It is low moisture absorption.	-50°F – 302°F -46°C – 150°C	Class 150 – 1500 PN 20 – 250	For high pressure high temperature offshore services.
Nylon+MoS2	Molon (Nylon+MoS2) is a modified Nylon, the characteristics are similar to Devlon with it is cheaper than Devlon.	-20°F – 266°F -29°C – 130°C	Class 150 – 1500 PN 20 – 250	For high pressure, low temperature services.
PEEK	PEEK is a high performance engineered thermoplastic. It is excellent in water/chemical resistance and it is unaffected by continuous exposure to hot water/steam	-148°F – 500°F -100°C – 260°C	Class 150 – 2500 PN 20 – 420	For high pressure high temperature services.
PPL	PPL (Polyparaphenylene) is an excellent seat material with low coefficient of friction, highly resistant to pressure and temperature.	-50°F – 482°F -46°C – 250°C	Class 150 – 300 PN 20 – 50	For high temperature low pressure services.
Delrin®	Delrin® (Acetal Resin) possesses high tensile strength, creep resistance and toughness. It exhibits low moisture absorption. It is chemically resistant to hydrocarbons, solvents and neutral chemicals. DO NOT use it on oxygen service or steam.	-50°F – 194°F -46°C – 90°C	Class 150 – 600 PN 20 – 100	For extreme pressure services.
TFM	TFM (modified PTFE) is a chemically modified PTFE that offers enhanced properties while retaining all the proven advantages of a conventional PTFE.	-112°F – 248°F -80°C – 120°C	Class 150 PN 20	For services requiring high purity.
Metal	Metal (typically stellite) seats are used in severe conditions where flashing, hydraulic shock, abrasive media or trapped metal may exist in the line.	Varies	Varies	For severe services.

O-RING MATERIALS

Material Name	Description	Operating Temperature	Operating Pressure
NBR	Buna-N (NBR) is an all purpose polymer with good resistance to water, solvents, oil and hydraulic fluids.	-50°F – 176°F -46°C – 80°C	Class 150 – 600 PN 20 – 100
HNBR	HNBR (Hydrogenated NBR) has similar media stability to NBR but with significantly better heat and oxidization stability.	-67°F – 337°F -55°C – 170°C	Class 150 – 600 PN 20 – 100
Viton	Viton (fluorocarbon) is a fluorocarbon elastomer that is compatible with a broad range of chemicals. It performs well in mineral acids, salt solutions, chlorinated hydrocarbons and petroleum oils	-49°F – 320°F -22°C – 204°C	Class 150 – 600 PN 20 – 100
EPDM	EPDM has good abrasion and tear resistance with excellent chemical resistance to a variety of acids and alkalines. It is susceptible to attack by oil, strong acids and strong alkalines and should not be used in compressed air lines.	-50°F – 302°F -46°C – 150°C	Class 150 – 600 PN 20 – 100
FVMQ	Fluorosilicone is a silicone polymer chain with fluorinated side-chains for improved oil and fuel resistance. The mechanical and physical properties are very similar to those of silicone.	-50°F – 320°F -46°C – 177°C	Class 150 – 600 PN 20 – 100
AFLAS®	AFLAS® is highly resistant to a wide range of chemicals	-49°F – 428°F -29°C – 220°C	Class 150 – 600 PN 20 – 100

TRUNNION BALL VALVE

FLOW COEFFICIENT

SPECIFICATION TABLE

Nominal Size in/mm	Class 150 PN 20		Class 300 PN 50		Class 600 PN 100		Class 900 PN 150		Class 1500 PN 250	
	Cv	Kv	Cv	Kv	Cv	Kv	Cv	Kv	Cv	Kv
1/2	25	21	25	18	20	17	16	14	16	14
3/4	56	48	56	40	4	3	34	29	34	29
1	95	81	95	69	64	54	55	47	55	47
1 1/2	308	262	308	223	308	262	165	140	165	140
2	500	425	430	361	370	315	320	272	320	272
3	1,360	1,156	1,100	983	1,020	867	920	782	820	697
4	2,500	2,125	2,000	1,806	1,850	1,573	1,760	1,496	1,600	1,360
6	4,060	3,451	4,056	2,933	3,410	2,899	4,300	3,655	4,150	3,528
8	8,090	6,877	7,700	5,845	6,730	5,721	8,475	7,204	8,010	6,809
10	13,510	11,484	13,090	9,761	11,120	9,452	14,160	12,036	13,220	11,237
12	20,440	17,374	19,830	14,768	17,440	14,824	21,200	18,020	18,800	15,980
14	25,050	21,293	23,770	18,099	22,010	18,709	26,700	22,695	24,180	20,553
16	34,200	29,070	32,595	24,710	29,980	25,483	36,600	31,110	33,150	28,178
18	44,430	37,766	43,200	32,101	39,520	33,592	49,000	41,650	45,703	38,848
20	57,665	49,015	55,380	41,663	50,450	42,883	64,600	54,910	60,750	51,638
22	70,080	59,568	70,080	50,633	68,900	58,565				
24	87,680	74,528	84,720	63,349	76,630	65,136				
28	120,000	102,000	115,350	86,700	107,510	91,384				
30	141,850	120,573	136,600	102,487	125,630	106,786				
32	160,390	136,332	152,200	115,882	140,900	119,765				
36	205,450	174,633	192,995	148,438	239,160	203,286				
40	248,700	211,395	248,700	179,686	239,160	203,286				
42	275,260	233,971	275,260	198,875	275,260	233,971				
48	364,180	309,553	364,180	263,120	364,180	309,553				
56	529,430	450,016	529,430	382,513	520,500	442,425				

CALCULATION OF FLOW COEFFICIENT

Flow coefficient Cv (Kv is the metric equivalent) is the rate of flow in gallon per minute with the pressure drop of 1psi across the valve. The flow coefficients shown in the above table are determined with equations as follows:

For liquids:

$$Q_l = C_v(\Delta P / SG)^{1/2}$$

Where:

Q_l = Flow of liquid (gallon/minute)
 ΔP = Pressure drop in psi (P₁-P₂)
 SG = Specific gravity (1 for liquid)

For gases (non-critical):

$$Q_g = 61 \cdot C_v(P_2 \cdot P_1 / SG)^{1/2}$$

Where:

Q_g = Flow of gases (SFH at STP)
 P₂ = Outlet pressure (psi)
 P₁ = Inlet pressure (psi)
 SG = Specific gravity (1 for gas)

TRUNNION BALL VALVE

VALVE FIGURE NUMBER

HOW TO ORDER

Nominal Size	Valve Type	Pressure Rating	End Conn.	Construction	Body Material	Trim Material	Seat or Insert	O-ring	Operation Mode
A	B	C	D	E	F	G	H	I	J
e.g. 1 6	B A	6	R	4	C 1	1 0	N	1	G

is a NPS 16 Class 600 trunnion ball valve, RF flanged, 3-piece split body, A105 body, SS316 trim, Nylon seat insert, Viton O-ring, gear operated.

A Nominal Size

oo Modified	o2 2 (DN 50)	o7 8 RB	19 20 RB	31 32 RB
F1 3/8 (DN 10)	R2 2 RB	o8 8 (DN 200)	20 20 (DN 500)	32 32 (DN 800)
F2 1/2 (DN 15)	F6 2 1/2 (DN 65)	o9 10 RB	21 22 RB	33 34 RB
oR 1/2 RB	3R 2 1/2 RB	10 10 (DN 250)	22 22 (DN 550)	34 34 (DN 850)
F3 3/4 (DN 20)	o3 3 (DN 80)	11 12 RB	23 24 RB	35 36 RB
Ro 3/4 RB	R3 3 RB	12 12 (DN 300)	24 24 (DN 600)	36 36 (DN 900)
o1 1 (DN 25)	o4 4 (DN 100)	13 14 RB	25 26 RB	37 38 RB
R1 1 RB	R4 4 RB	14 14 (DN 350)	26 26 (DN 650)	38 38 (DN 950)
F4 1 1/4 (DN 32)	o5 5 (DN 125)	15 16 RB	27 28 RB	39 40 RB
1R 1 1/4 RB	R5 5 RB	16 16 (DN 400)	28 28 (DN 700)	40 40 (DN 1000)
F5 1 1/2 (DN 40)	o6 6 (DN 150)	17 18 RB	29 30 RB	41 42 RB
2R 1 1/2 RB	R6 6 RB	18 18 (DN 450)	30 30 (DN 750)	... More as such

B Valve Type

BA Ball Valve

C Pressure Rating

o Modified	7 Class 2500
1 Class 150	9 Class 900
3 Class 300	8 Class 800
5 Class 1500	2 Class 125
6 Class 600	4 Class 400

D End Connection

X Other	B Butt-Weld (BW)
R RF Flanged	S Socket-Weld (SW)
J RTJ Flanged	
F FF Flanged	
T Threaded	

E Construction

o Other
3 2PC Body Trunnion
4 3PC Body Trunnion
6 Welded Body Trunnion

F Body Material

Xo Other	E7 A182 F91	S6 A351 CF8M	A1 B564 No4400(Monel 400)
C1 A105N	E8 A217 C12A	S7 A182 F316L	A2 A494 M-35-1
C2 A216 WCA	L1 A350 LF1	S8 A351 CF3M	A3 B865 No5500(Monel K500)
C4 A216 WCB	L2 A352 LCA	S9 A182 F347	A4 B462 No8020(Alloy 20)
C6 A216 WCC	L3 A350 LF2	So A351 C F8C	A5 A351 CN7M(Cast Alloy 20)
M1 A182 F1	L4 A352 LC2	SA A182 F317	A6 A990 CN3MCU(Cast Alloy 20)
M2 A217 WC1	L5 A350 LF3	SB A182 F321	A7 B462 N10276 (Hastelloy C276)
M3 A182 F2	L6 A352 LC3	SC A182 F304H	A8 A494 CW12MW(Cast Hastelloy Alloy C276)
M4 A217 WC4	L7 A350 LF5	SD A351 CF10	B1 B564 No6625 (Alloy Inconel 625)
M5 A182 F12 CL 2	L8 A352 LCB	SE A182 F316H	B2 A494 CW6MC(Cast Inconel Alloy 625)
M6 A217 WC5	L9 A350 LF6	SF A351 CF10M	B3 B564 No8825 (Alloy Inconel 825)
M7 A182 F11 CL 2	LA A350 LF9	SG A182 F304(L) Dual	B4 A494 CW5MCUC(Cast Inconel Alloy 825)
M8 A217 WC6	LB A352 LC9	SH A182 F316(L) Dual	H1 B62 C83600 Composition Bronze Casting
M9 A182 F22 CL 3	LD A352 LCC	D1 A182 F51	H2 B148 C95400 Al-Bronze Casting
Mo A217 WC9	S1 A182 F304	D2 A995 4A	H3 B148 C95800 Al-Bronze Casting
E1 A182 F5	S2 A351 CF8	D3 A182 F53	H4 B150 C63000 Al-Bronze Rod, Bar
E2 A217 C5	S3 A182 F304L	D4 A995 5A	H5 B150 C63200 Al-Bronze Rod, Bar
E5 A182 F9	S4 A351 CF3	D5 A182 F55	
E6 A217 C12	S5 A182 F316	D6 A995 6A	

TRUNNION BALL VALVE

VALVE FIGURE NUMBER (CONT'D)

HOW TO ORDER

Nominal Size	Valve Type	Pressure Rating	End Conn.	Construction	Body Material	Trim Material	Seat or Insert	O-ring	Operation Mode
A	B	C	D	E	F	G	H	I	J
e.g. 1 6	B A	6	R	4	C 1	1 0	N	1	G

is a NPS 16 Class 600 trunnion ball valve, RF flanged, 3-piece split body, A105 body, SS316 trim, Nylon seat insert, Viton O-ring, gear operated.

G Trim Material

00	Other	25	F53/F53/F53	41	A105+Ni60/A105+Ni55/4140+ENP
01	F6a/F6a/410	26	A105+ENP/A105+ENP/F316	42	A105+Ni60/A105+Ni60/17-4PH
02	304/304/304	27	304+ENP/304+ENP/304+ENP	44	Inconel 625/Inconel 625/Inconel 625
09	Monel/Monel/Monel	28	Inconel 625/Inconel 625/F316	45	316+ENP/316+ENP/F316
10	316/316/316	29	A105+ENP/A105+ENP/4140+ENP	46	316+ENP/316+ENP/F316+ENP
13	Alloy 20/Alloy 20/Alloy 20	30	A105+ENP/A105+ENP/A105+ENP	47	316+Ni60/316+Ni55/17-4PH
19	A105+ENP/A105+ENP/F6a	31	316/316/17-4PH	48	316L+Ni60/316L+Ni55/17-4PH
20	304L/304L/304L	36	LF2+ENP/LF2+ENP/F6a	49	316+Ni60/316+Ni55/4140+ENP
21	316L/316L/316L	37	A105+TCC/A105+TCC/17-4PH	50	316L+Ni60/316L+Ni55/4140+ENP
22	F321/F321/F321	38	A105+TCC/A105+TCC/4140+ENP		
23	F55/F55/F55	39	A105+TCC/A105+TCC/F51		
24	F51/F51/F51	40	A105+ENP/A105+ENP/17-4PH		

H Seat or Seat Insert

X	Other	M	Metal
T	PTFE	V	Viton
R	RPTFE	H	HNBR
P	PCTFE	E	EPDM
N	Nylon		
D	Devlon		
P	PEEK		

I O-Ring

0	No O-ring
1	Viton
2	Teflon
3	HNBR
4	NBR
5	Special
6	EPDM
7	FVMQ
8	FFKM
9	AFLAS

J Operation

L	Lever
D	Lever w/ locking device
G	Gearbox
F	Gearbox w/ locking device
C	Gear w/chain
B	Bare stem
P	Pneumatic
N	Pneumatic-Hydraulic
E	Electric
Q	Other

HOW THE FIGURE NUMBER SYSTEM WORKS

Introduction. Figure number system uses a code consisting 14 digits of letters and numbers to represent the specification of a valve of certain specification. Among 14 digits, they are separated into 10 groups identified by letters from A to J. Each group represents a parameter of a valve, together they contain almost all the essential parameters of the valve.

Uses. Using the figure number system to generate a code is easy. Under each group, the code is shown on the left while on the right is the meaning of the code. Start by selecting a code from group A, through group J. If the specification of the valve is not listed, select the code for "Other/Modified". The total length of the figure number shall be exactly 14 digits.

Cautions. It is advised that you have as detailed the specification as possible to generate a figure number, which means eliminating "Other/Modified". If you don't have enough specification or information about the valve you are ordering, or you're not sure how to use the system to generate a figure number, contact one of our sales representatives for help.

Note: FBV reserves the right to make any modifications without notice.



Offshore



Onshore

Pipeline



Refinery



IMPORTANT NOTICE

- All dimensions in inches not listed in standards are converted from millimeters. Weights in lbs (pounds) are converted from kilograms.
- Data listed in the catalog, including dimensions, weights, specifications and other valve related data are intended to provide general information and guidance only.
- FBV Inc. assumes no responsibility for errors or inadequacy relevant to any information provided in this catalog. Any information provided in this catalog is subject to change without notice.



CONTACT US

E : sales@fbvalve.com

W: www.fbvalve.com

©FBV Inc. All rights reserved.

FBV INC.(USA)

2121 FM 359 South
Brookshire, Texas 77423 USA
T: +1 832-203-5459

FBV Latam INC.

Obarrio, Calle 54 Este, PH Atrium
Tower, Piso 23, Ofc. 23-08
Ciudad de Panama Panama
T: +507-388-7480

FBV INC.(China)

815 Bihu Industrial Zone
Lishui, Zhejiang 323000
T: +86 (577) 8836-7328

FBV (SEA) PTE LTD.

1 Scotts Road, #24-10,
Shaw Centre
Singapore 228208
T: +65-6681-5772